

QUICK REFERENCE GUIDE



LAND CRUISER

2024



2024

Land Cruiser

This Quick Reference Guide is a summary of basic vehicle operations. It contains brief descriptions of fundamental operations so you can locate and use the vehicle's main equipment quickly and easily.

The Quick Reference Guide is not intended as a substitute for the Owner's Manual located in your vehicle's glove box. We strongly encourage you to review the Owner's Manual and supplementary manuals so you will have a better understanding of your vehicle's capabilities and limitations.

Your dealership and the entire staff of Toyota Motor North America, Inc. wish you many years of satisfied driving in your new Land Cruiser.

A word about safe vehicle operations

This Quick Reference Guide is not a full description of Land Cruiser operations. Every Land Cruiser owner should review the Owner's Manual that accompanies this vehicle.

Pay special attention to the boxed information highlighted in color throughout the Owner's Manual. Each box contains operating instructions to help you avoid injury or equipment malfunction.

All information in this Quick Reference Guide is current at the time of printing. Toyota reserves the right to make changes at any time without notice.

INDEX

OVERVIEW

Engine maintenance	13
Fuel tank door release and cap	12
Hood release	12
Indicator symbols	8-9
Instrument cluster	6-7
Instrument panel	2-5
Instrument panel light control	11
Keyless entry ^{1,2}	10-11
Smart Key system ^{1,2}	11

FEATURES & OPERATIONS

Air conditioning/heating ^{1,2}	36-37
Audio Multimedia	31
Auto lock/unlock ^{1,2}	14
Blind Spot Monitor (BSM) ² and Rear Cross Traffic Alert (RCTA) ²	52
Clock	15
Cool box	39
Crawl Control	46-47
Digital Key	16
Door lock switches	14
Downhill assist control system	42
Driver Monitor Alert ²	57
Driving mode select switches	45
Electric parking brake	19
Four wheel drive selector	41
Front and Rear Parking Assist with Automatic Braking (PA w/AB)	54-55
Front Cross Traffic Alert (FCTA) ²	60
Front seats-Adjustments	22
Garage door opener (HomeLink®) ³	35
Head-Up Display (HUD) ²	29
Heated/ventilated seats	38
Heated steering wheel	38
Hybrid transmission	18
i-FORCE MAX Hybrid System	17
Intuitive parking assist ²	51
Lane Change Assist (LCA) ²	61
Lights ^{1,2} & turn signals	25
Moonroof ¹	27
Multi-Information Display (MID) ^{1,2}	28
Multi-Terrain Monitor ²	56
Multi-Terrain Select	48-49
Power liftgate ^{1,2}	20-21
Power outlet-12V DC	33
Power outlet-120V AC	33
Power windows ¹	14
Qi Wireless charger	34
Rear Camera Detection (RCD) ²	50
Rear differential lock	39

FEATURES & OPERATIONS (continued)

Rear seats-Adjustments	23
Rear seats-Folding 2nd row seats	23
Rear view monitor system	49
Safe Exit Assist (SEA) ²	53
SDM (Stabilizer with Disconnection Mechanism)	43
Seats-Head restraints	24
Steering wheel switches & telephone controls (Bluetooth®)	30
Tilt and telescopic steering wheel	15
TOW HAUL switch	47
Traffic Jam Assist (TJA) ²	58-59
Trailer brake controller	44
USB Type-C charge ports	32
USB Type-C media port	32
Vehicle Stability Control (VSC)/TRAC/ Trailer sway control OFF switch	40
Windshield wipers & washers	26

TOYOTA SAFETY SENSE™ 3.0

Automatic High Beams (AHB)	76-77
Cruise Control	74-75
Full-Speed Range Dynamic Radar Cruise Control (DRCC)	71-74
Lane Departure Alert (LDA) with Steering Assist	68-70
Lane Tracing Assist (LTA)	67
Over-The-Air (OTA) Updates	63
Pre-Collision System with Pedestrian Detection (PCS w/PD)	64-66
Proactive Driving Assist (PDA)	79-81
Quick overview- Toyota Safety Sense™ 3.0	62-63
Road Sign Assist (RSA)	77-78
Sensors	63

SAFETY & EMERGENCY FEATURES

Floor mat installation	88
Rear door child safety locks	82
Safety Connect®	83
Seat belts	82
Seat belts-Shoulder belt anchor	82
Spare tire & tools	84-85
Star Safety System™	86-87
Tire pressure warning system (TPWS)	85

GETTING STARTED WITH TOYOTA AUDIO MULTIMEDIA AND CONNECTED SERVICES

90-100

¹ Visit your Toyota dealer for information on customizing this feature.

² Programmable by customer. Refer to the "Owner's Manual" for instructions and more information.

³ HomeLink® is a registered trademark of Gentex Corporation.

Instrument panel

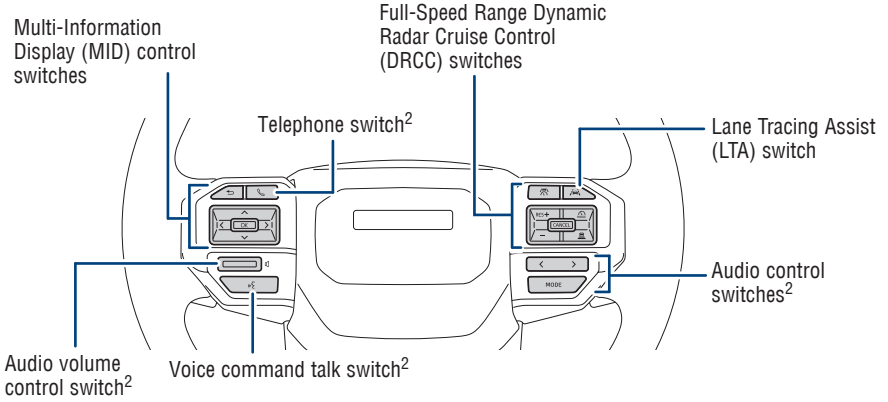

Steering wheel controls

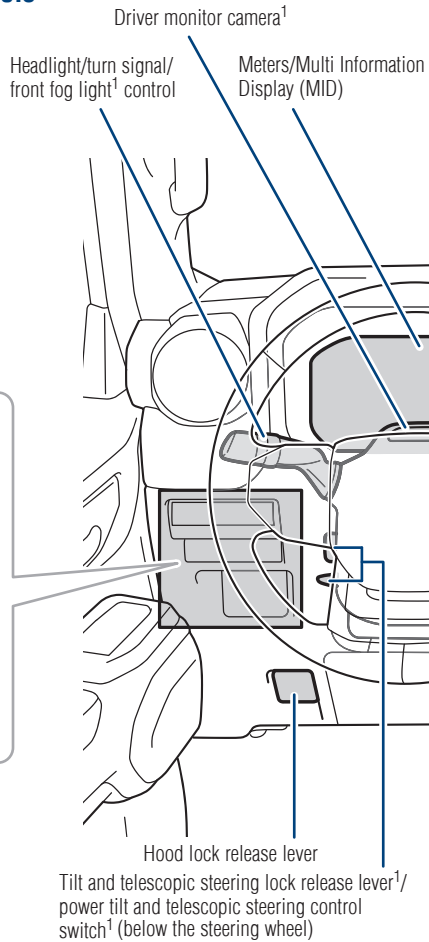

Switches (refer to page 4)

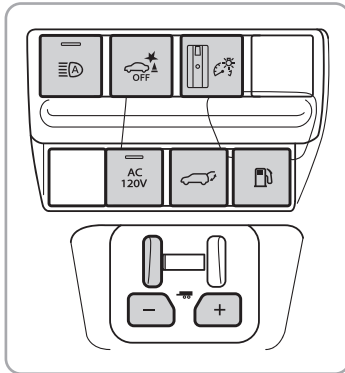

¹ If equipped.

² For details, refer to the "Multimedia Owner's Manual" or visit www.toyota.com/audio-multimedia for additional resources.

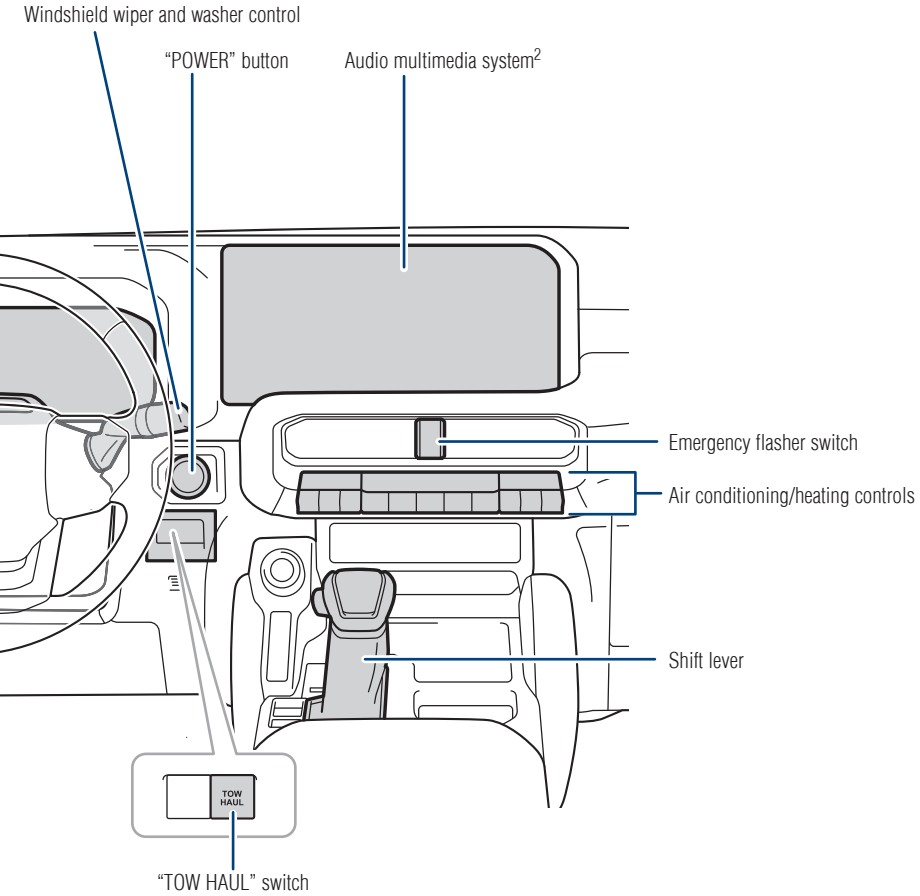

Instrument panel (continued)

SWITCHES

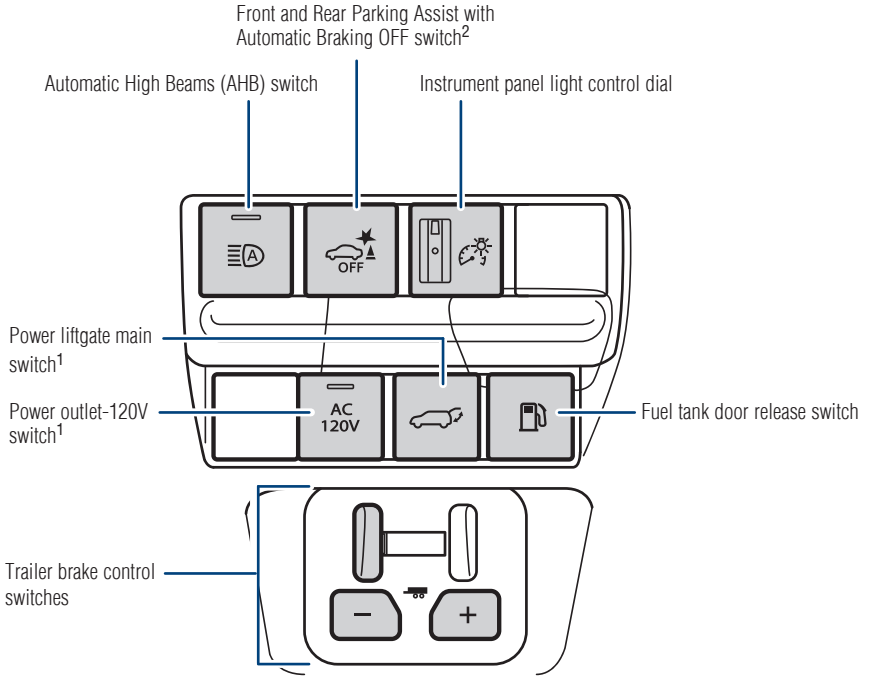

CENTER CONSOLE AREA

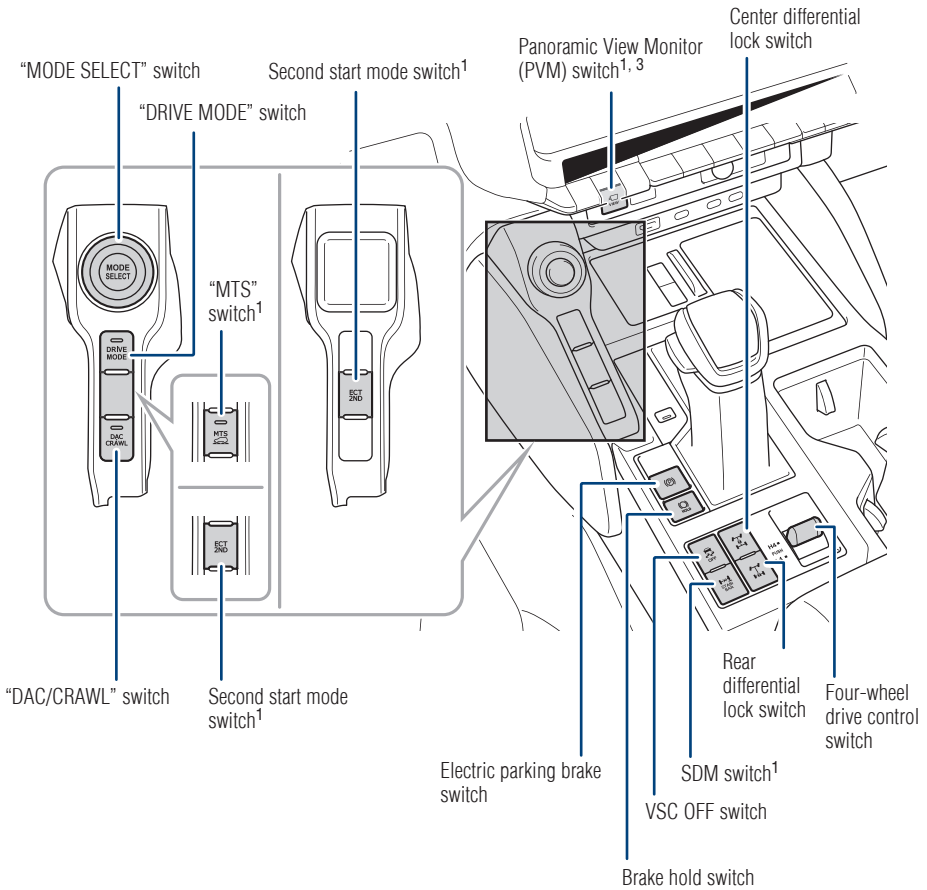

¹ If equipped

² Refer to section PKSB (Parking Support Braking function) in the “Owner’s Manual”.

³ Vehicles with panoramic view monitor, refer to “Multimedia Owner’s Manual”.

OVERVIEW

Instrument cluster

VEHICLES EQUIPPED WITH 7-in DISPLAY

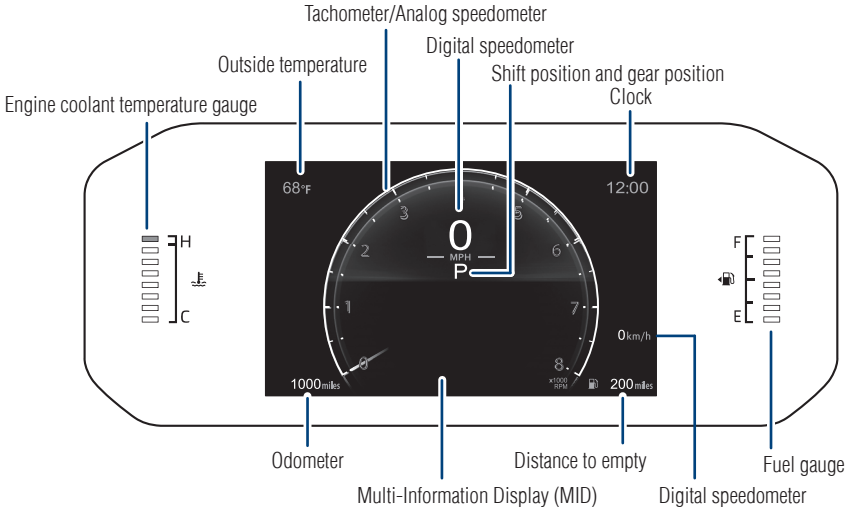

VEHICLES EQUIPPED WITH 12.3-in DISPLAY

Type 1/Type 3

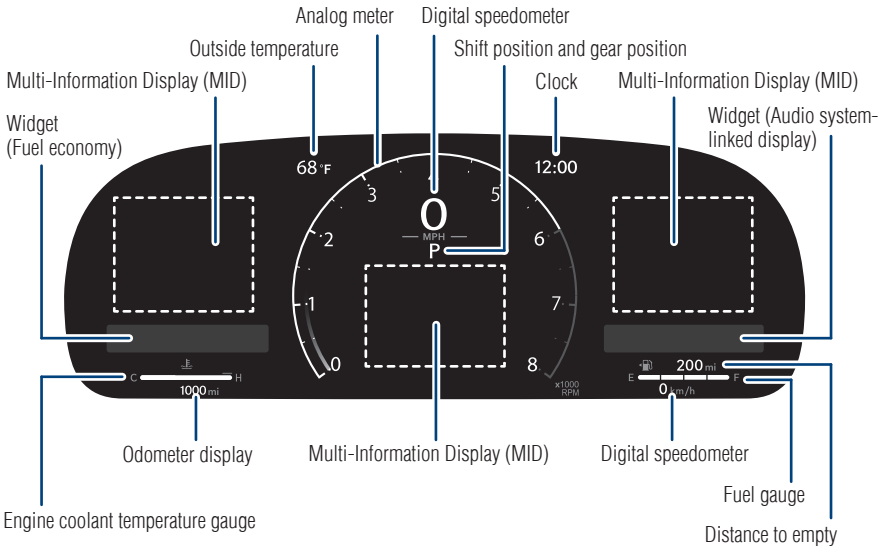

VEHICLES EQUIPPED WITH 12.3-IN DISPLAY (CONTINUED)



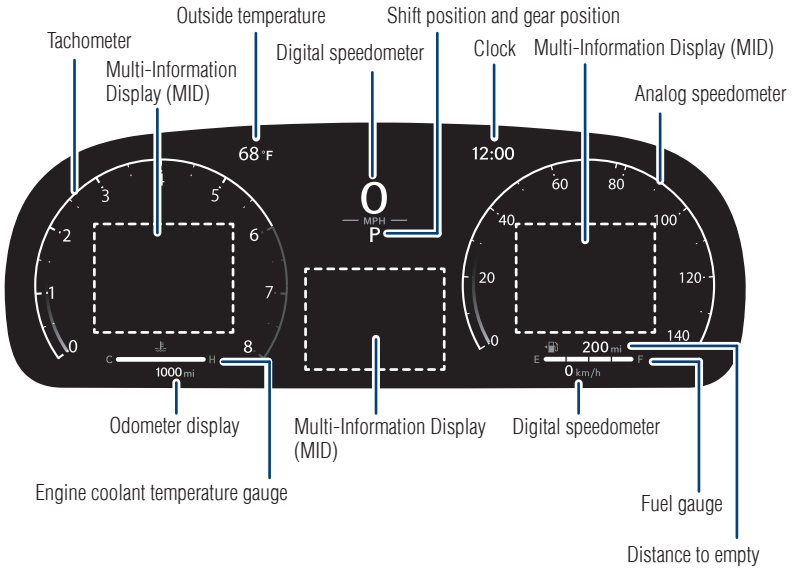





















Type 2

































OVERVIEW

Indicator symbols

For details, refer to “Warning lights and indicators”, Section 2, 2024 “Owner’s Manual”.

 ABS	ABS (Anti-lock Brake System) warning ¹		Driver and front passenger seat belt reminder ⁵ (alarm will sound when the vehicle is on)
 A	AHB (Automatic High Beams) indicator		Driving assist information indicator ¹
	AUTO mode indicator ⁴		ECO drive mode indicator
 HOLD	Brake hold operating indicator ^{1,2,5}		Electric power steering system warning ¹ [red/yellow]
	Brake hold standby indicator ¹		Front fog light indicator
 BRAKE	Brake system warning ^{1,5}		Full-Speed Range Dynamic Radar Cruise Control (DRCC) indicator ⁵ [white/green/yellow]
	Brake system warning ^{1,5} [yellow]		Headlight low/high beam indicators
	Charging system warning ⁵		High coolant temperature warning ⁵
	Crawl control indicator ¹		Inappropriate pedal operation warning ⁵
	Center differential lock indicator ²		Intuitive parking assist detection indicator
	DEEP SNOW mode indicator ⁴		Intuitive parking assist OFF indicator ^{1,5}
	DIRT mode indicator ⁴		LDA (Lane Departure Alert) indicator ⁵ [white/green/yellow ³]
	Downhill assist control system indicator ¹		

	Low engine oil pressure warning ⁵		ROCK mode indicator ⁴
	Low fuel level warning		SDM indicator ⁴
	Low outside temperature indicator		Second start mode indicator ⁴
	Low speed four-wheel drive indicator ²		SAND mode indicator ⁴
	Low tire pressure warning ^{1,5}		Security indicator
	LTA (Lane Tracing Assist) indicator ⁵ [white/green/yellow ³]		Slip indicator ^{1,3}
	Malfunction/Check Engine indicator ¹		Smart Key system indicator
	MUD mode indicator ⁴		Sport mode indicator
	Outside rear view mirror indicators		SRS warning ¹
	Parking brake indicator ^{2,5}		Stop light indicator
	PASSENGER AIR BAG indicator		TOW HAUL indicator
	PDA (Proactive Driving Assist) indicator ⁵ [white/green/yellow]		Trailer brake warning
	PCS (Pre-Collision System) warning ^{1,5}		Turn signal indicator
	READY indicator		VSC (Vehicle Stability Control) OFF indicator ¹
	Rear differential lock indicator ²		
	Rear passengers' seat belt reminder ⁵		

¹ If the indicator does not turn off within a few seconds of starting the engine, there may be a malfunction. Have the vehicle inspected by your Toyota dealer.

² If the indicator flashes, there may be a malfunction. Refer to the "Owner's Manual".

³ If the indicator flashes, it indicates that the system is operating.

⁴ If equipped.

⁵ With buzzer sound.

OVERVIEW

Keyless entry

UNLOCKING OPERATION

Smart Key

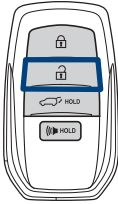

Press

ONCE: Driver door
TWICE: All doors

Carry Smart Key remote

Driver door unlock*

Grasp

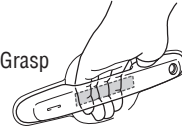

NOTE: If a door is not opened within 60 seconds of unlocking, all doors will relock for safety.

LOCKING OPERATION

Smart Key



Press

Carry Smart Key remote

All-door lock

Touch



LIFTGATE OPERATION (LOCKING/UNLOCKING)

Smart Key



Press and hold

Carry Smart Key remote

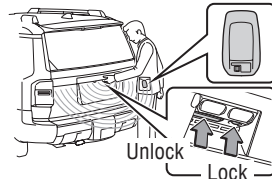

* Driver door unlocking function can be programmed to unlock driver door only, or all doors. If change the door unlock setting, grasping front passenger door handle will unlock all doors.

Please refer to the "Owner's Manual" for more details on how to program the doors.

NOTE: Doors may also be locked/unlocked using the mechanical key. (Slide the release button on the back of Smart Key and take the mechanical key out.)

PANIC BUTTON

Smart Key

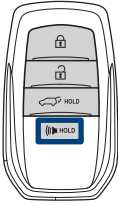

 HOLD
Press and hold



Smart Key system

START FUNCTION

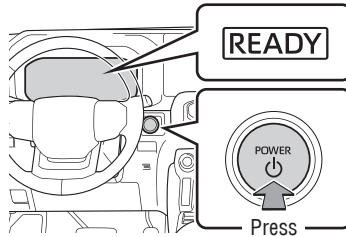

NOTE: The Smart Key must be carried to enable the start function. With the shift lever in Park and the brake pedal depressed, press the power button.

POWER (WITHOUT STARTING VEHICLE)

Without depressing the brake pedal, pressing the power button will change the operation mode in succession from:

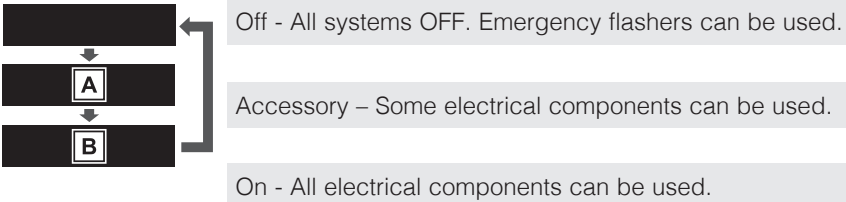

A - "ACCESSORY", **B** - "POWER ON"

Instrument panel light control

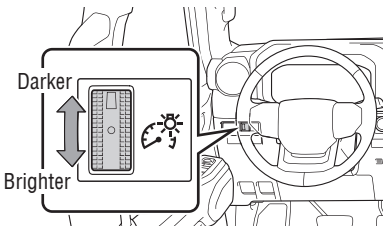

The brightness of the instrument panel lights can be adjusted.

Fuel tank door release and cap

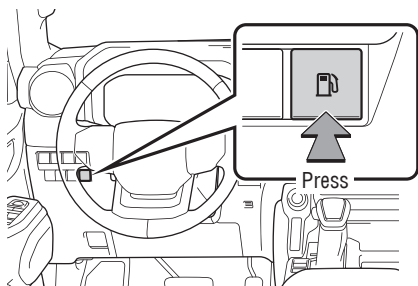

Opening

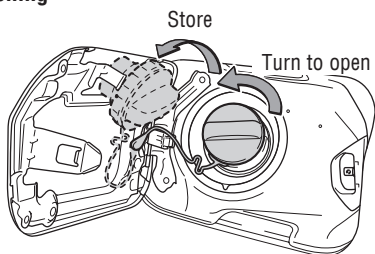

Closing

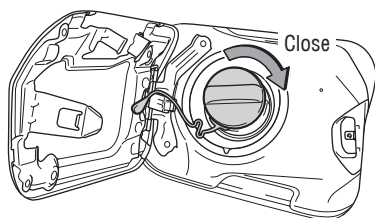

NOTE: Tighten until one click is heard. If the cap is not tightened enough, the message “Check Fuel Cap” will appear on the Multi-Information Display (MID).

Hood release

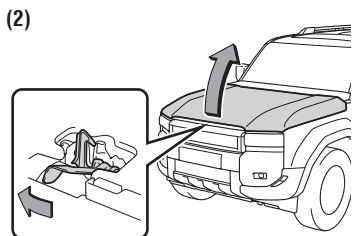
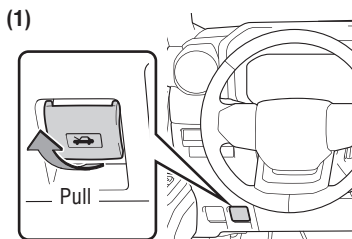

Push the auxiliary catch lever to the left and lift the hood.

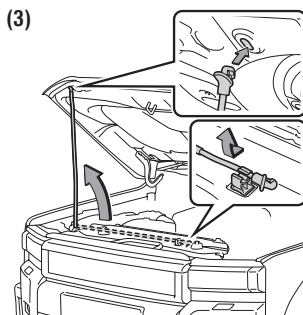

Insert the supporting rod to hold the hood open.

Engine maintenance

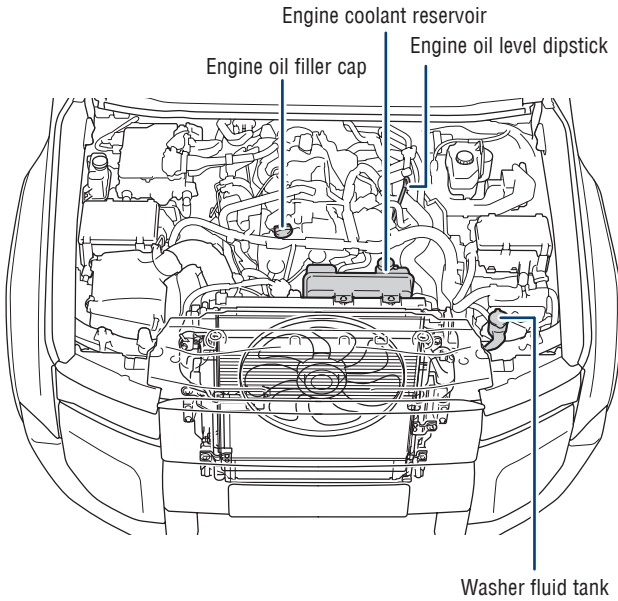

NOTE: Regularly scheduled maintenance at your Toyota dealer, including oil changes, will help extend the life of your vehicle and maintain performance. *Please refer to the “Warranty & Maintenance Guide”.*

FEATURES & OPERATIONS

Auto lock/unlock

Automatic door locks can be programmed to operate in different modes, or turned OFF.

DEFAULT SETTING

Shift position linked door unlocking function

- Doors unlock when shifting into Park.

Speed linked door locking function

- Doors lock when the vehicle speed is approximately 12 mph (20 km/h) or higher.

CUSTOMIZED SETTING

Shift position linked door locking function

- Doors lock when shifting from Park.

Driver's door linked door unlocking function

- Doors unlock when the driver's door is opened within approximately 45 seconds after the vehicle is turned off.

Refer to the "Owner's Manual" for more details.

Door lock switches

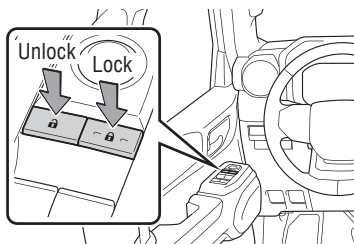

Power windows

Driver side

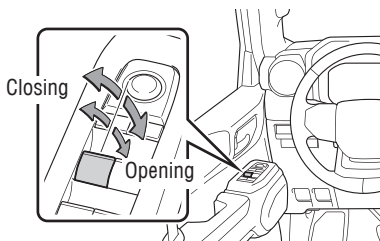

Window lock switch

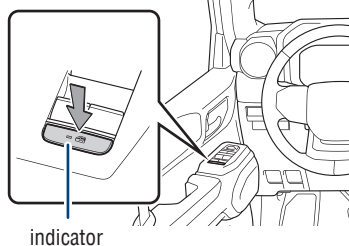

All window auto up/down

Push the switch completely down or pull it completely up and release to fully open or close. To stop the window partway, operate the switch in the opposite direction.

Window lock switch

Deactivates all passenger windows. Driver's window remains operable.

Clock

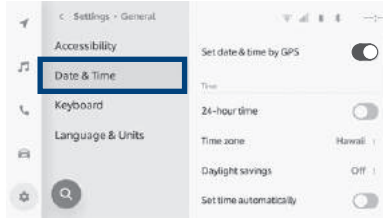

- 1) Press “” button on the main menu.
- 2) Select “**General**” on the submenu.
- 3) Select “**Date & Time**”.
- 4) Select the desired items to be set.

NOTE: It is recommended to “Set date & time by GPS” feature to ON for automatic time updates based on your location.

Refer to the “Multimedia Owner’s Manual” for more details.

Tilt and telescopic steering wheel

MANUAL

POWER

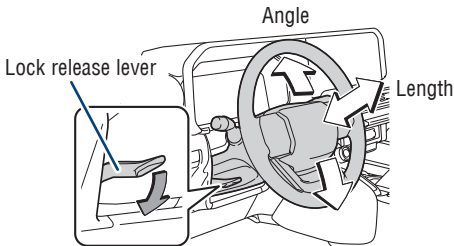

Hold the steering wheel, push the lever down, set angle and length, and return the lever.

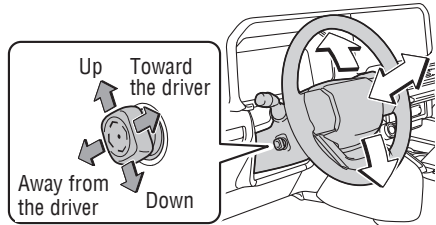

Toggle the control switch to set angle and length.

NOTE: Do not attempt to adjust while the vehicle is in motion.

Automatic tilt-away & returning function (if equipped)

When the vehicle is turned off, the steering wheel is automatically adjusted to a position that allows driver to enter and exit the vehicle easily.

When the power button has been turned “ACCESSORY” or “POWER ON”, the steering wheel automatically returns to the original position.

Power easy access system (if equipped)

The steering wheel and driver’s seat move in accordance with the power button mode and the driver’s seat belt condition.

FEATURES & OPERATIONS

Digital key (if equipped)

A smartphone can be used instead of the electronic key of the vehicle by installing the dedicated Digital Key App on a smartphone. Also, Digital Key can be shared with your family or friends using the Digital Key App.

Install the Toyota App and register the Vehicle to the customer's Toyota App profile, and subscribe to Remote Services, and enroll in Digital Key.

Digital key precautions:

- A Digital Key can be used when the smartphone and server can communicate. The Digital Key may become unusable if the smartphone is not connected to the Internet. Be sure to carry the electronic key of the vehicle if traveling to a location with unreliable communications.
- If the smartphone battery is depleted, the smartphone cannot be used as Digital Key. If the battery level is low, be sure to charge the smartphone prior to going out.
- The Digital Key system is related to the smart key system. If the smart key system has been deactivated in the vehicle customization setting, the Digital Key will also be disabled.
- Depending on the radio wave environment, the Digital Key may not be able to be used.
- When transferring vehicle ownership, make sure to delete the Digital Keys.
- If the vehicle is not operated for 14 days or more, the Digital Key will not connect automatically. Therefore, it may take some time before the system operates after a door handle is touched.
- A part of the services may be stopped for a certain period of time due to server maintenance. However, registered Digital Keys can be used during the maintenance.
- A smartphone with the Digital Key App enabled will be able to lock and unlock the doors, start the engine and perform any other operations as same as the electronic key of the vehicle. Be especially careful not to lose the smartphone or allow it to be stolen. If the smartphone is lost or stolen, contact your Toyota dealer immediately.
- When taking your vehicle to a Toyota dealer for an inspection or repairs, make sure to bring an electronic key.
- With the Digital Key alone, no vehicle lights will illuminate when approached to the vehicle.

Free/open source software information

This product contains Free/open source software (FOSS).

License information and/or the source code of this FOSS can be obtained at the following URL:

<https://www.denso.com/global/en/opensource/dkey/toyota/>

i-FORCE MAX Hybrid System

The i-FORCE MAX system utilizes a computer controlled gasoline engine and an electric motor located in-between the engine and transmission to provide the most efficient combination of power for the vehicle. When the brakes are applied, the motor will act as a generator to provide charging energy for the traction battery, as well as provide braking force in conjunction with the service brakes to slow the vehicle. In addition, the engine may shut off when the vehicle comes to a stop to reduce fuel consumption and emissions. The engine will automatically restart as needed.

NOTE: Fuel consumption of the Hybrid System is shown on the multimedia system.

TIPS FOR IMPROVED FUEL ECONOMY

- Ensure tire pressures are maintained at levels specified in the “*Owner’s Manual*”.
- When possible, link trips to reduce engine cold starts.
- Avoid driving at speeds that are higher than necessary, especially on the highway.
- When possible, avoid sudden stops to maximize regenerative braking energy.
- Minimize use of the air conditioning.

STARTING THE HYBRID SYSTEM

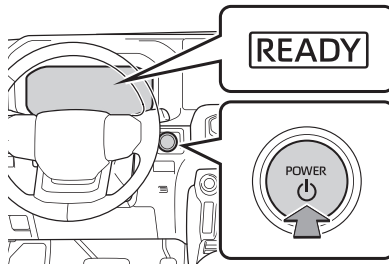

- (1) Put the shift lever in “P”.
- (2) Depress the brake pedal, and “” and a message will be displayed on the Multi-Information Display (MID).
- (3) Press the “POWER” button briefly and firmly.
- (4) Continue depressing the brake pedal until the “READY” indicator is illuminated. If the “READY” indicator turns on, the hybrid system will operate normally. Shift the lever to the desired position and you may begin driving.

FEATURES & OPERATIONS

Hybrid transmission

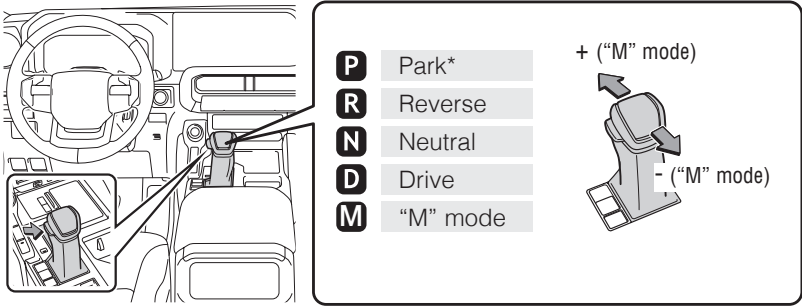

* The vehicle must be on and the brake pedal depressed to shift from Park.

"M" MODE

Shift the shift lever to "M" position from "D" position.

- + : Upshift (push and release)
- : Downshift (pull and release)

Downshifting increases power going uphill, or provides engine braking downhill. For best fuel economy during normal driving conditions, always drive with the shift lever in the "D" position.

SECOND START MODE (IF EQUIPPED)

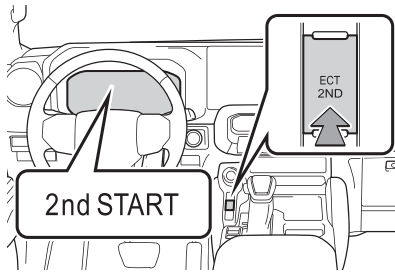

The second start mode is designed to accelerate and drive on slippery road surfaces such as snow.

Refer to the "Owner's Manual" for more information.

Electric parking brake

PARKING BRAKE

Automatic mode (shift lever operation)

To turn automatic mode ON, while vehicle is stopped, pull and hold the parking brake switch until a buzzer sounds and a message is shown on the Multi-Information Display (MID).

While depressing the brake pedal, shifting the lever into P position will automatically set the brake and turn the parking brake indicator light on.

To release the brake, depress the brake pedal and shift the lever out of P. The indicator will turn off.

To turn automatic mode OFF, press and hold the parking brake switch until a buzzer sounds and a message is shown on the MID.

Manual mode

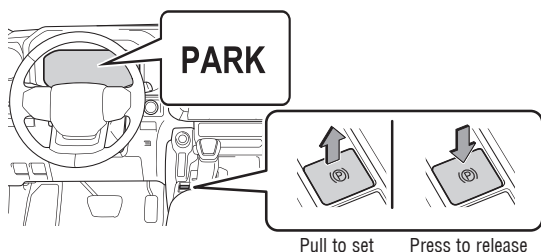

While the vehicle is stopped and the brake pedal is depressed, pull the switch to set the parking brake and turn the parking brake indicator light on. To release, depress the brake pedal and press the switch. The indicator will turn off.

Refer to the "Owner's Manual" for limitations and more details.

BRAKE HOLD

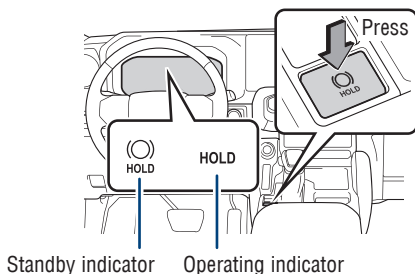

The brake hold system keeps the brake applied when the shift lever is in D, M, N or P while the system is on and the brake pedal has been depressed to stop the vehicle. The system releases the brake when the accelerator pedal is depressed with the shift lever in D or M to allow smooth start off.

Refer to the "Owner's Manual" for limitations and more details.

FEATURES & OPERATIONS

Power liftgate (if equipped)

OPENING/CLOSING OPERATION

Using the Smart Key



 HOLD
Press and hold

From the inside

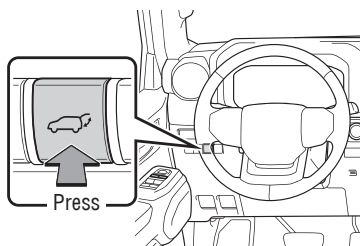

Opener switch on liftgate

- Opening -

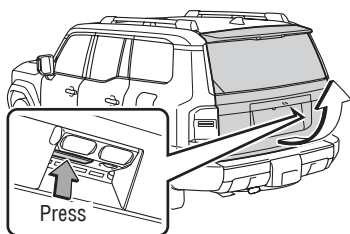

- Close without lock -

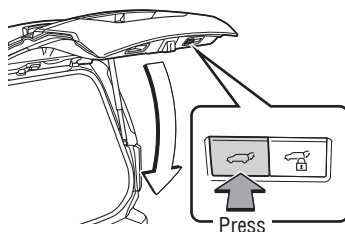



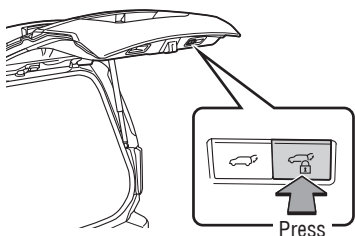

- Close and lock -

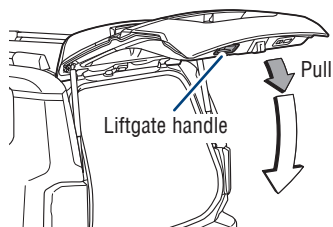

Liftgate handle











- Closing -



Press “<>” or “◇” of the MID control switches and select “PBD” from the “ Vehicle Settings” in the “”^{*1} or “”^{*2} screen on the Multi-Information Display (MID) to access hands-free settings. And press “” to enter selection.

^{*1} 7-in display, ^{*2} 12.3-in display

HEIGHT ADJUSTABLE FUNCTION

1. When the liftgate reaches the desired height, press the “” switch (on the door jam of the liftgate) once. Press and hold the switch until the buzzer sounds (4 times).
2. To reset the height, with the liftgate open and not moving, press and hold the “” switch until the buzzer sounds 4 times, and continue to hold until it buzzes again, then let go. Press the same button to close the liftgate. When you open the liftgate next time, it will open to the maximum height.
3. To set the height using the Multi-Information Display (MID), press “< >” or “” of the MID control switches and select “ Vehicle settings” from “”^{*1} or “”^{*2} screen. Press “< >” or “” and select “PBD” and then press “”. Select “Opening angle”, then press “”. Select desired position (5 height options to choose from,) then press “”.

NOTE: If battery is disconnected, the power back door needs to be reinitialized.

^{*1} 7-in display, ^{*2} 12.3-in display

Refer to the “Owner’s Manual” for limitations and more details.

FEATURES & OPERATIONS

Front seats-Adjustments

MANUAL SEAT (IF EQUIPPED)

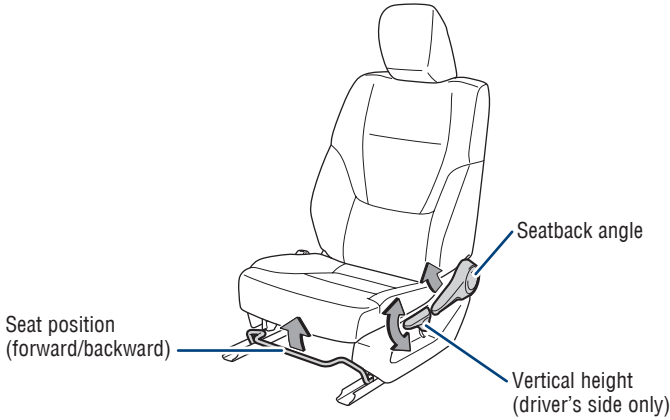

POWER SEAT (IF EQUIPPED)

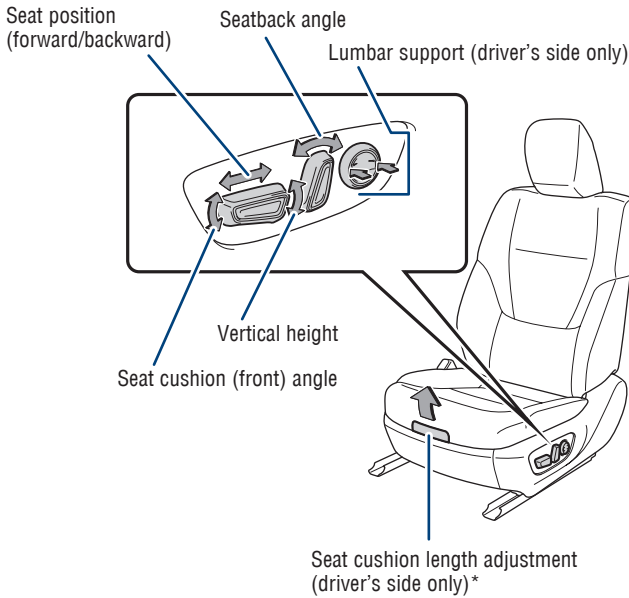

* If equipped

Power easy access system (if equipped): The driver's seat and steering wheel move in accordance with power switch mode and the driver's seat belt condition.

Rear seats-Adjustments

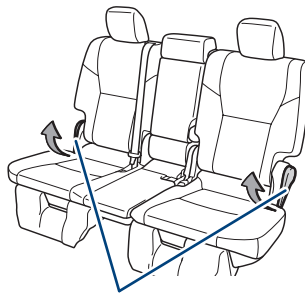

Seatback angle

Refer to the "Owner's Manual" for more details.

Rear seats-Folding 2nd row seats

Before tumbling the second seat, lower the head restraints to the lowest position and stow the second seatbelt buckles. And then stow the armrest.

(1)

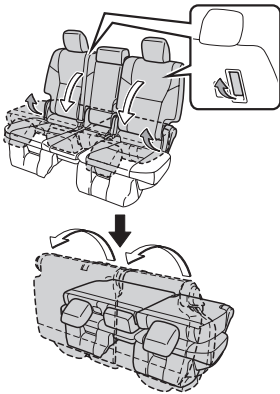

Pull the seatback adjustment lever or tumble lever on the seatback of the second seat.

The seatback is folded forward and the seat springs up.

(2)

Open the cover on the back of the seat cushion, take out the tumble band and attach the band to the assist grip.

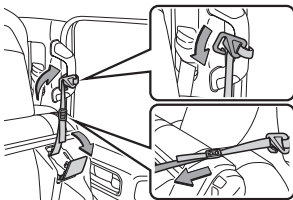

(3)

Remove the seat hook covers from the back of the seat cushion, and install them on the seat hooks.

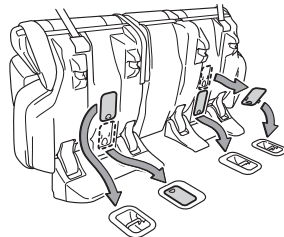

FEATURES & OPERATIONS

Seats-Head restraints

FRONT AND OUTBOARD SECOND SEATS

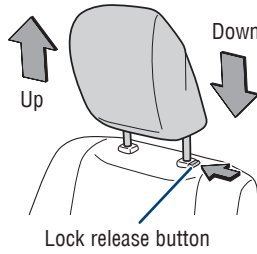

REAR

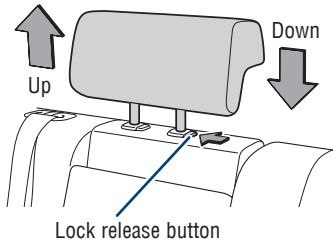

Lights & turn signals

HEADLIGHTS

Operating the  switch turns on the headlight indicator.

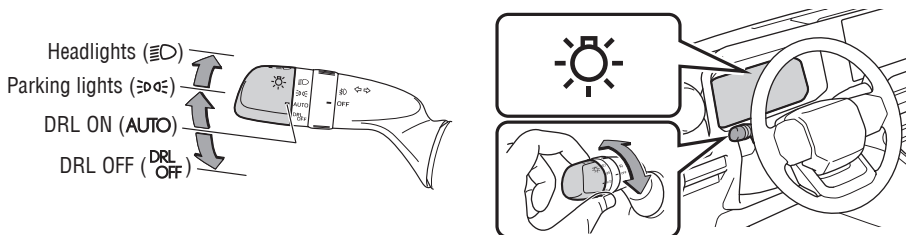

Daytime running light (DRL) system

Automatically turns on under certain conditions to make vehicle more visible to other drivers. Not for use at night. (The parking brake needs to be released and the headlight switch must be in the “☾” or the “AUTO” position while the vehicle is on.)

Automatic light cut off system

- Headlights are on: The headlights and taillights will turn off automatically 30 seconds after the vehicle is turned from ON to OFF and the driver's door is opened and closed. (If the “” switch on the Smart Key remote is pressed after all the doors are locked, the lights will turn off immediately.)
- Only the taillights are on: The taillights will turn off automatically if the vehicle is turned from ON to OFF and the driver's door is opened.

Automatic High Beams system (AHB)*

Automatically switches between high and low beams as appropriate to enhance vision at night.

Refer to Toyota Safety Sense™ 3.0 in this guide or the “Owner's Manual” for more details on the Automatic High Beams feature.

* Operating conditions must be met. Refer to the “Owner's Manual” for details.

FRONT FOG LIGHTS

TURNING SIGNALS

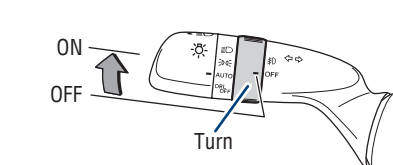

Fog lights come on when the headlights are on in low beam.

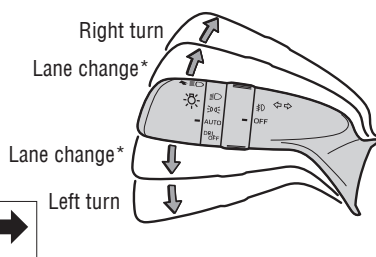

* Move the lever partway and release. The signals will flash three times.

FEATURES & OPERATIONS

Windshield wipers & washers

FRONT

Adjust frequency*

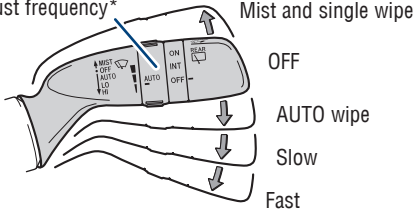

Pull to wash and wipe

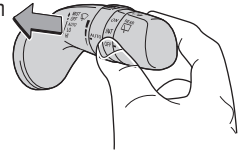

* **Rain-sensing windshield wiper sensitivity adjustment:** Rotate to increase/decrease the sensitivity.

REAR

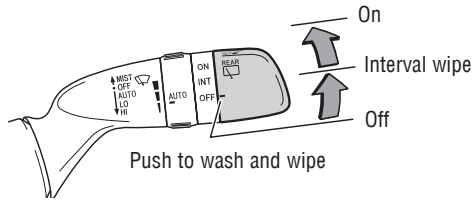

Cleaning the rear back-up camera

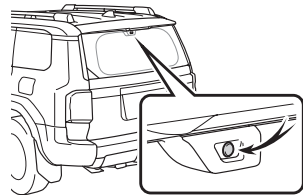
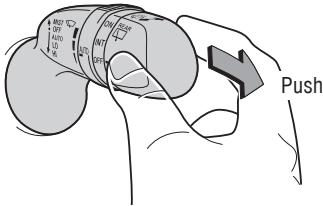

Rear back-up camera

Pushing the lever operates the wiper and washer. The wiper will automatically operate a couple of times after the washer squirts. The washer will automatically operate and clean the rear back-up camera*.

* Refer to the "Multimedia Owner's Manual".

Moonroof (if equipped)

SLIDING OPERATION

Press once to open partway.
Press again to open completely.

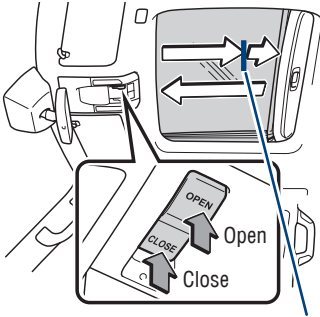

Recommended open position to minimize wind noise.

TILTING OPERATION

Press once to open completely.

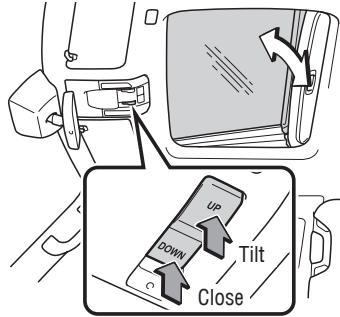

Lightly press either side of the moonroof switch while opening/tilting is in progress, the moonroof stops partway.





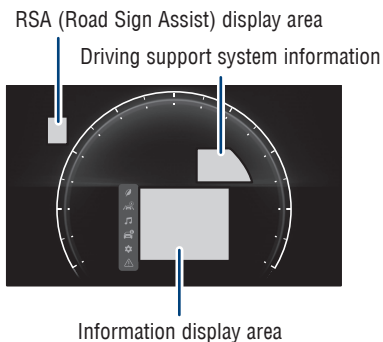

FEATURES & OPERATIONS

Multi-Information Display (MID)

VEHICLES EQUIPPED 7-in DISPLAY



Press MID control switches to change and select information in the following:

-  Driving information display
-  Driving support system information display
-  Audio system-linked display
-  Vehicle information display
-  Settings display
-  Warning message display

VEHICLES EQUIPPED 12.3-in DISPLAY

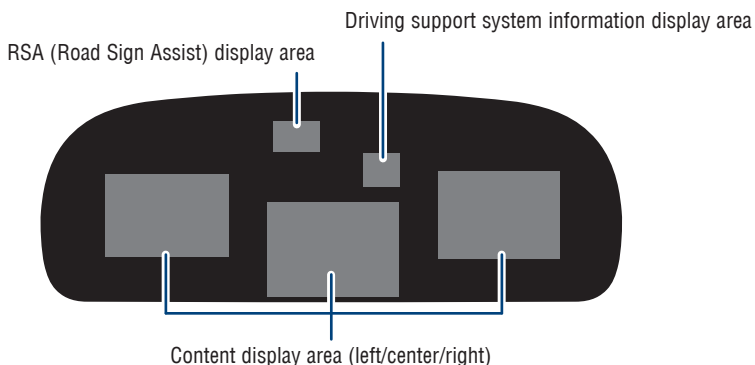

MID CONTROL SWITCHES

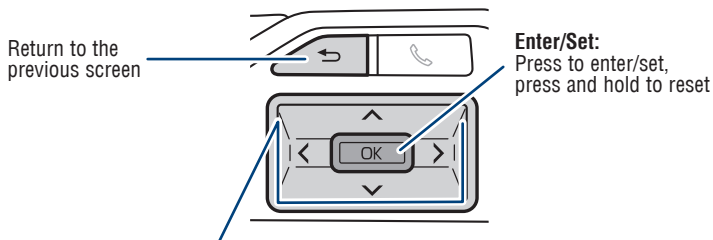

“<>” or “⬆️”

Press to select an item/change pages

Refer to the “Owner’s Manual” for more information.

Head-Up Display (HUD) (if equipped)

The head-up display projects a variety of driving-related information and the operating state of the driving support systems on the windshield.

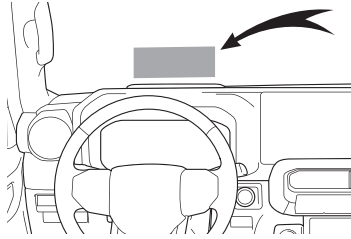

DISPLAY TYPE

Full

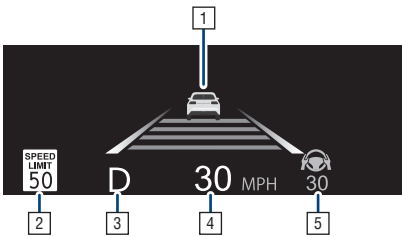

Standard

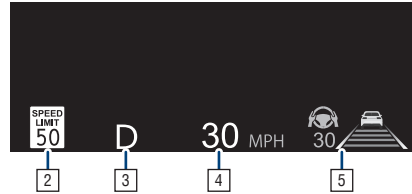

Minimum

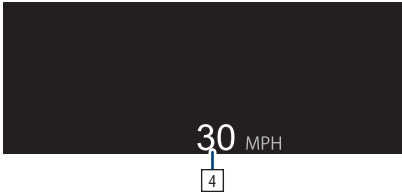

- 1 Driving support system display area/
Navigation system-linked display area*/
Tachometer display area
- 2 RSA (Road Sign Assist) display area
- 3 Shift position/gear position
- 4 Speedometer
- 5 Driving support system display area*

* If equipped

Press MID control switches and select “”^{*1} or “”^{*2} on the Multi-Information Display (MID) and press “” to enter selection.

^{*1} 7-in display, ^{*2} 12.3-in display

Refer to the “Owner’s Manual” for more details.

FEATURES & OPERATIONS

Steering wheel switches & telephone controls (Bluetooth®)

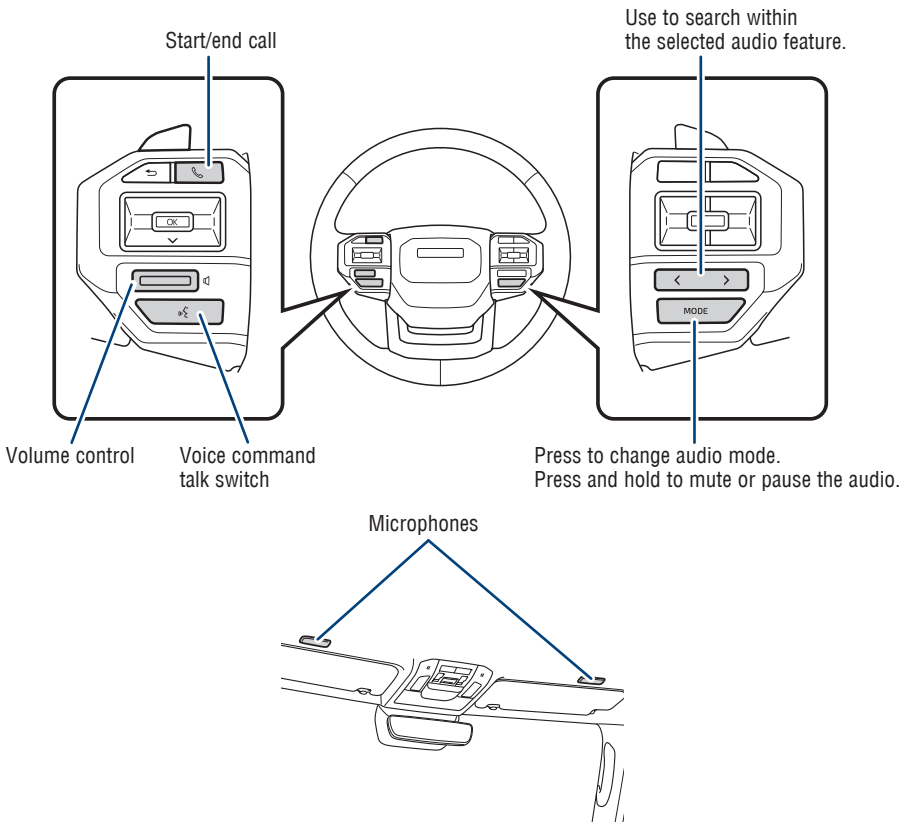

Bluetooth® technology allows dialing or receipt of calls without removing your hands from the steering wheel.

Refer to the Bluetooth® device pairing in this guide or the "Multimedia Owner's Manual" for additional user instructions.

NOTE: Always use safe driving practices and follow all traffic rules.

Audio Multimedia

VEHICLES EQUIPPED WITH 8-in DISPLAY

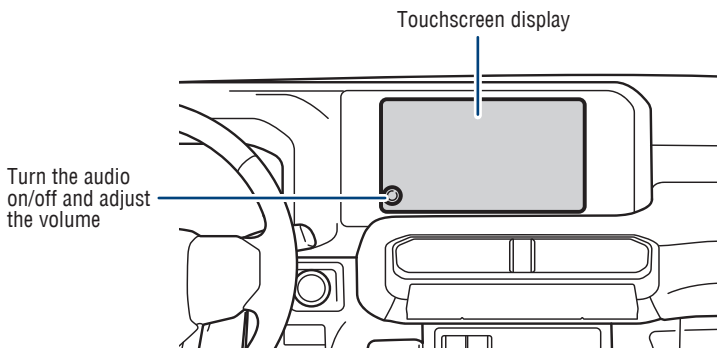

VEHICLES EQUIPPED WITH 12.3-in DISPLAY

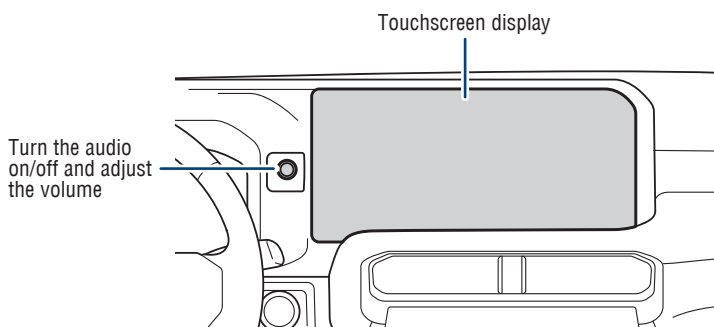

Refer to the "Multimedia Owner's Manual" or visit www.toyota.com/audio-multimedia for additional resources.

NOTE: Always use safe driving practices and follow all traffic rules.

FEATURES & OPERATIONS

USB Type-C media port

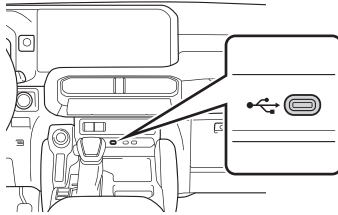

Connecting a compatible device and cable into the USB media port will support charging and music playback through the audio multimedia system.

USB Type-C charge ports

FRONT

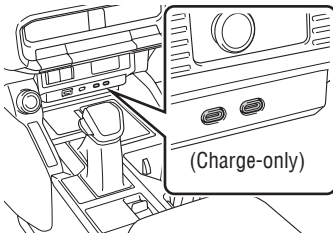

CONSOLE BOX

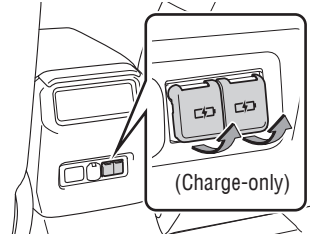

REAR (IF EQUIPPED)

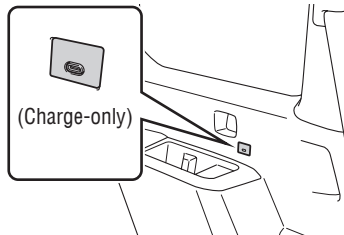

The vehicle must be in the "ACCESSORY" or "POWER ON" mode for use.

Power outlet-12V DC

Rear of console box

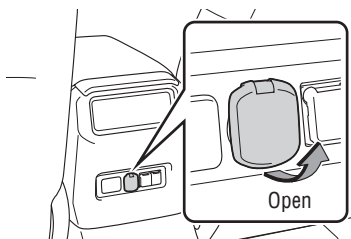

Luggage compartment (if equipped)

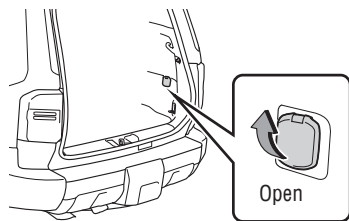

The vehicle must be in the “ACCESSORY” or “POWER ON” mode for use.

Power outlets-120V AC (if equipped)

OUTLET LOCATION

Luggage compartment

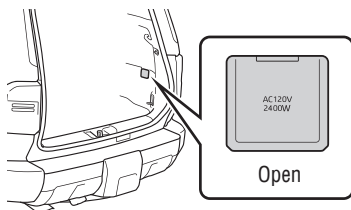

POWER OUTLET ON/OFF MASTER SWITCH

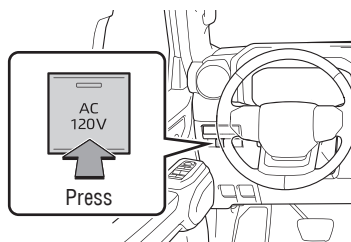

Press the AC 120V master switch. The power outlets can be used when the indicator on the AC 120 V master switch is illuminated.
To turn off the 120 V outlets, press the master switch and observe that the switch is no longer illuminated.

Refer to the “Owner’s Manual” for more details.

Qi Wireless charger (if equipped)

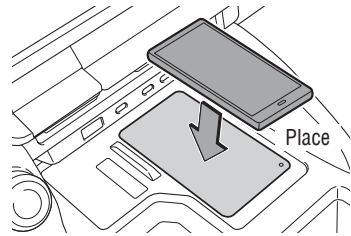
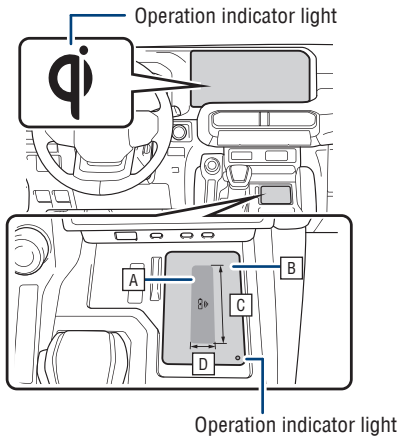

Place device nearest in the center of the charging area for best results. If the charging coil is not in the center of the device, place the device so that its charging coil is centered in the charging area.

- A** Charge area
- B** Charging tray
- C** Approximately 3.9 in. (10 cm)
- D** Approximately 1.0 in. (2.5 cm)

A mobile device can be charged wirelessly on the tray. Place a compatible mobile device on the tray as shown in the illustration. An orange indicator illuminates while charging is in progress. When charging is complete, the indicator illuminates green. Some phones, cases or cover type wireless chargers may not cause the green indicator to illuminate even though it is fully charged.

The vehicle must be in the “ACCESSORY” or “POWER ON” mode for use.

Refer to the “Owner’s Manual” for limitations and more details on this system before attempting to use it.

Garage door opener (HomeLink®)* (if equipped)

VEHICLES WITH AUTO ANTI-GLARE INSIDE REAR VIEW MIRROR

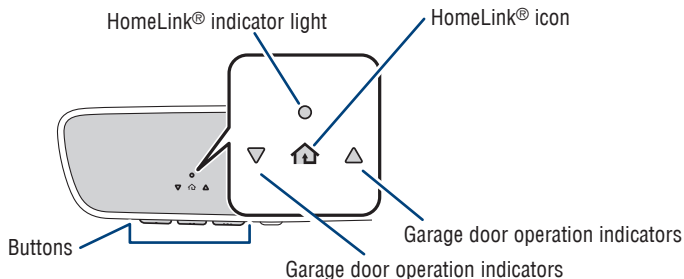

VEHICLES WITH DIGITAL REARVIEW MIRROR

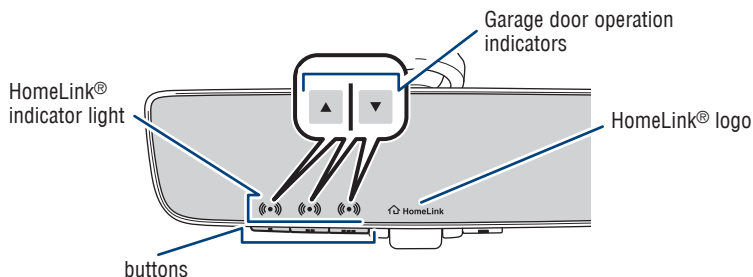

Garage door openers manufactured under license from HomeLink®* can be programmed to operate garage doors, estate gates, security lighting, etc.

Refer to the "Owner's Manual" for more details.

For programming assistance, contact HomeLink® at 1-800-355-3515, or visit www.homelink.com/toyota.



* HomeLink® is a registered trademark of Gentex Corporation.

FEATURES & OPERATIONS

Air conditioning/heating

FRONT AUTOMATIC AIR CONDITIONING SYSTEM

Automatic mode:

Adjusting the temperature setting will cause the airflow mode, air intake and fan speed to adjust automatically to the set temperature.

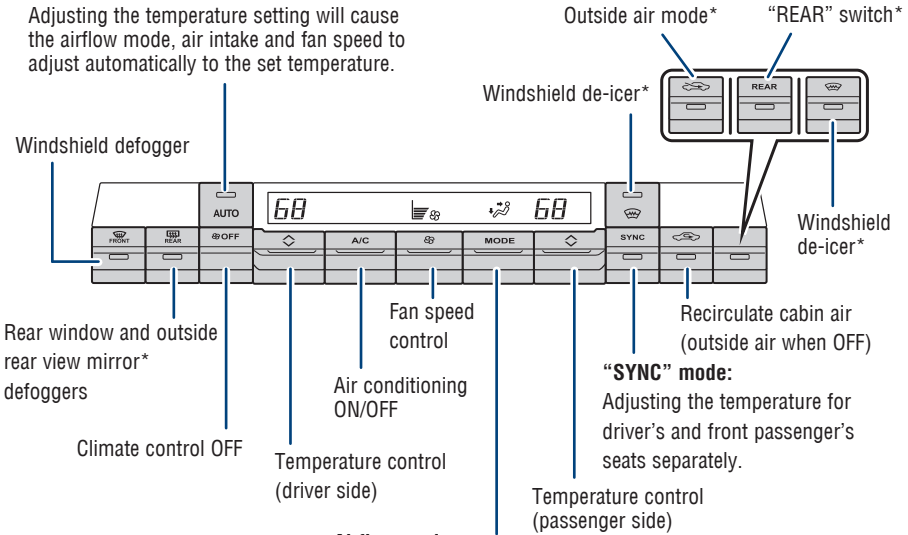

Airflow mode:

In "OFF" mode, use outside air ("OFF" indicator OFF) to reduce window fogging.



* If equipped

REAR AUTOMATIC AIR CONDITIONING SYSTEM (IF EQUIPPED)

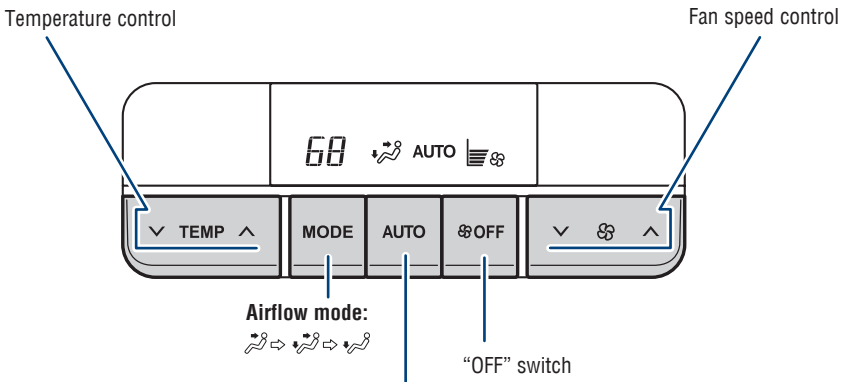

Automatic mode:

Adjusting the temperature setting will cause the airflow mode and fan speed to adjust automatically to the set temperature.

AIR CONDITIONING CONTROL SCREEN

- (1) Touch “” on the main menu on the Multimedia Display.
- (2) Touch “Climate” on the sub menu.
- (3) Select any screen.

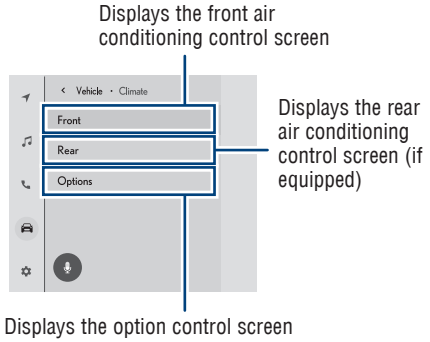

Front air conditioning control screen

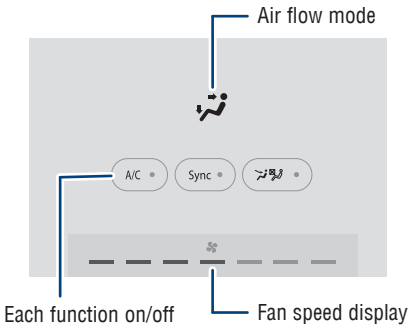

Rear air conditioning control screen (if equipped)

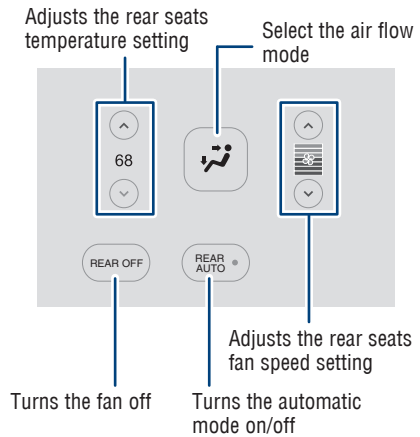

Option control screen

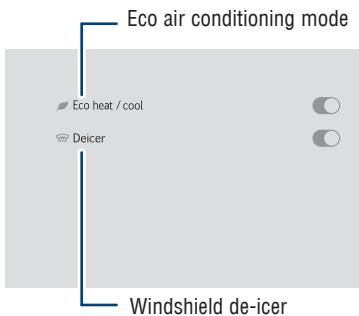

Refer to the “Owner’s Manual” for more details.

Heated steering wheel (if equipped)

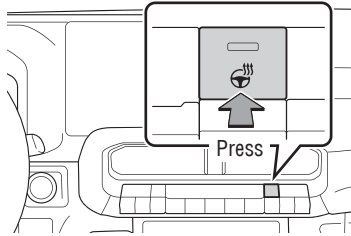

The vehicle must be on for use.

Heated/ventilated seats (if equipped)

HEATED SEAT OPERATION (IF EQUIPPED)

Front seats - Heated only

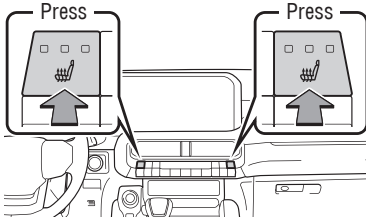

Front seats - Vehicles without ventilated seat

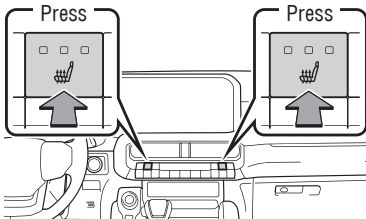

Outboard second seats (if equipped)

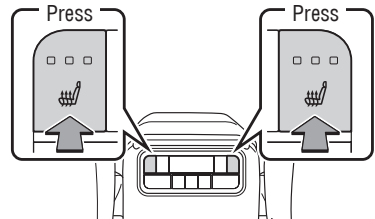

VENTILATED SEAT OPERATION (IF EQUIPPED)

Front seats

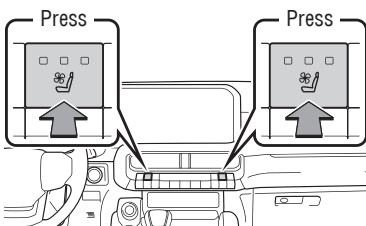

Outboard second seats (if equipped)

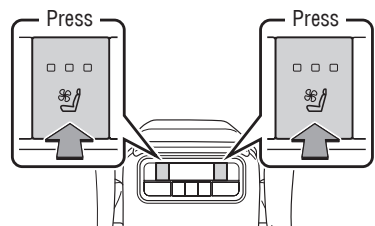

The vehicle must be on for use.

Cool box (if equipped)

Open the lid.

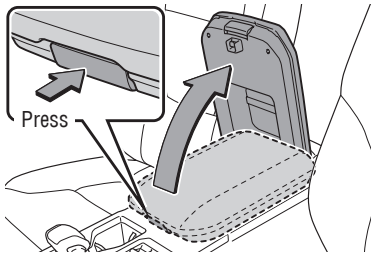

Turn the switch ON/OFF.

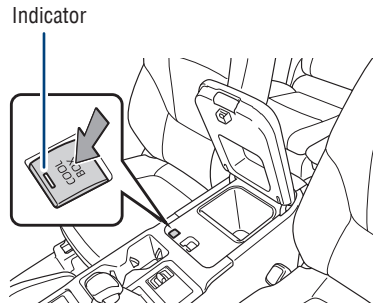

When the cool box is turned on, the front air conditioning system is automatically turned on.

The front air conditioning system cannot be turned off while the cool box is on.

Rear differential lock

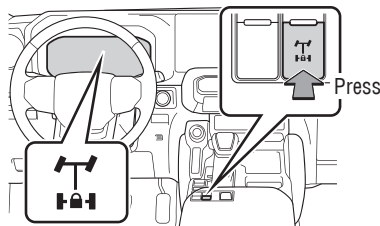

The rear differential lock system is provided for use only when wheel spinning occurs in a ditch or on a slippery or rugged surface. This system is effective in case one of the rear wheels is spinning.

The following systems do not operate when the rear differential is locked. (ABS/ Brake assist system/VSC/Downhill assist control system/TRAC)

Refer to your "Owner's Manual" for complete details on this system before attempting to use it.

FEATURES & OPERATIONS

Vehicle Stability Control (VSC)/TRAC/ Trailer sway control OFF switch

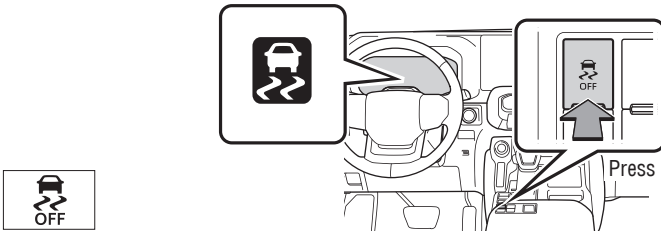

The VSC OFF switch can be used to help free a stuck vehicle in surroundings like mud, dirt or snow. While the vehicle is stopped, press the switch to disable the TRAC system.

To disable VSC/TRAC/Trailer Sway Control systems, press and hold the switch for at least 3 seconds while the vehicle is stopped.

Refer to the "Owner's Manual" for limitations and more details on this system before attempting to use it.

Four wheel drive selector

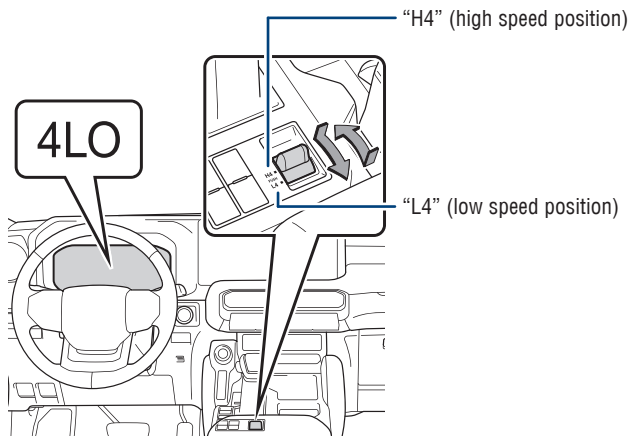
4LO**H4****High speed (4WD)** Normal driving on all types of roads.**L4****Low speed (4WD)**

For maximum power and traction when climbing or descending steep hills, off-road driving, and hard pulling in sand, mud or deep snow.

Shifting between “H4” and “L4”

- Shifting from “H4” and “L4”: Stop the vehicle completely and continue to depress the brake pedal, shift the shift lever to N. Then push and shift the front-wheel drive control switch to “L4”.
The “4LO” indicator will come on.
- Shifting from “L4” to “H4”: Stop the vehicle completely and continue to depress the brake pedal, shift the shift lever to N. Then push and shift the front-wheel drive control switch to “H4”.
The “4LO” indicator will go off.

Center differential lock switch

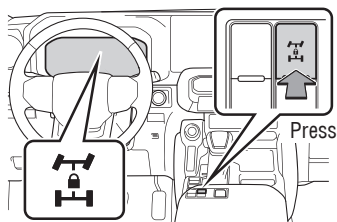

Lock the center differential when your vehicle’s wheels get stuck in a ditch or when driving on a slippery or bumpy surface.

Refer to the “Owner’s Manual” for limitations and more details on this system before attempting to use it.

Downhill assist control system

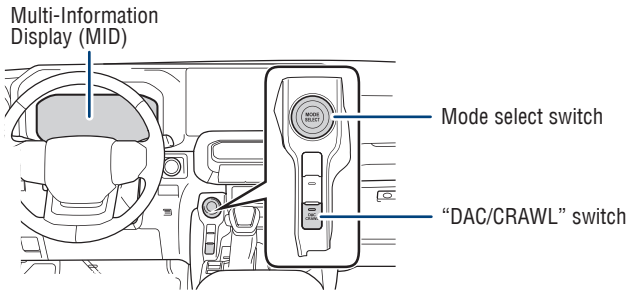

The downhill assist control system is designed to help to prevent excessive speed on steep downhill slopes. The system will operate when the vehicle is traveling under 18 mph (30 km/h) and transfer mode is in "H4".

SYSTEM OPERATION

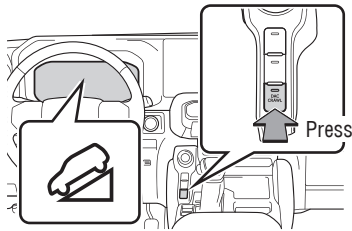

Press the "DAC/CRAWL" switch.

When the system is in operation, the slip indicator will flash, and the stop lights/high mounted stop lights will be lit. A sound may also occur during the operation. This does not indicate a malfunction.

Turning off the system

- When the "DAC/CRAWL" switch indicator illuminates: Press the "DAC/CRAWL" switch again.
- When the "DAC/CRAWL" switch indicator does not illuminate: Press the "DAC/CRAWL" switch to turn the indicator on. Press the "DAC/CRAWL" switch again with the indicator turned on.

SETTING SPEED

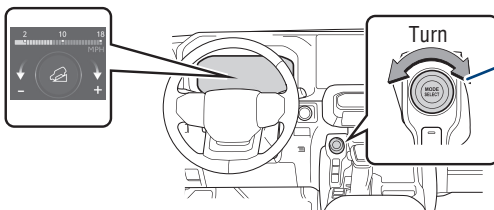

Turn the mode select switch to set the desired speed (approx. 3 mph [4 km/h] to 18 mph [30 km/h]).

Turn to left: decrease
Turn to right: increase

Refer to the "Owner's Manual" for limitations and more details on this system before attempting to use it.

SDM (Stabilizer with Disconnection Mechanism) (if equipped)

SDM (Stabilizer with Disconnection Mechanism) is a system that switches conditions of the front stabilizer to maintain vehicle stability and drivability on paved road and off-road situations.

Depending on the switch operation or vehicle speed, the stabilizer is locked/unlocked, which results in the following effects.

During driving on paved roads

The stabilizer is locked and the movement of the suspensions is restrained, resulting in stable driving.

During off-road driving

- The stabilizer is unlocked and it becomes easier that the suspensions extend and retract, leading to improvement of drivability on rough roads.
- The vibration of the vehicle body is reduced, which helps enhance riding comfort.

SYSTEM ON/OFF

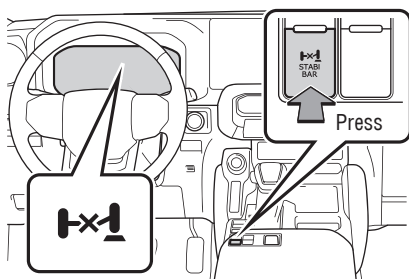

Press the SDM switch.

The stabilizer is unlocked and the SDM indicator will come on. Press the switch again to lock the stabilizer (the SDM indicator will turn off). While the stabilizer is being locked or unlocked, the SDM indicator flashes.

The vehicle must be ON and the vehicle speed is approximately 18 mph (30 km/h) or less. The stabilizer will be locked again when the vehicle speed exceeds approximately 18 mph (30 km/h).

Refer to the "Owner's Manual" for limitations and more details on this system before attempting to use it.

Trailer brake controller

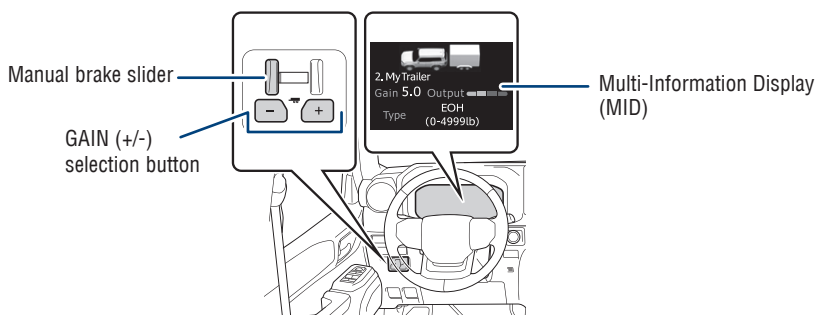

The trailer brakes can be controlled by the Trailer brake controller via the 7-pin connector. By selecting the type of brakes that are being used on the trailer (electric or electric-over-hydraulic) and setting the “gain” for the controller, the manual brake slider is used to slow just the trailer. The vehicle brake pedal will also slow down as well as stop the trailer when applied, also via the same connector. “Gain” values, manual brake outputs, trailer brake types and the trailer connection status are displayed on the Multi-Information Display (MID).

This vehicle comes equipped with a Toyota Genuine Trailer Brake Controller. Use of a third-party trailer brake controller along with the Toyota Genuine Trailer Brake Controller may have unexpected effects on the system.

Toyota does not recommend the use of a thirdparty brake controller with this vehicle.

CHANGING THE SETTING

- (1) Press “<>” or “◇” switches and select “⚙️”^{*1} or “⚙️”^{*2} from the Multi-Information Display (MID).
- (2) Press “<>” or “◇” switches and select “🚗⚙️ Vehicle Settings”, then press “OK”.
- (3) Press “<>” or “◇” switches and select “Trailer Brake Type” and then press “OK”.
- (4) Select the desired setting and then press “OK”.

^{*1} 7-in display, ^{*2} 12.3-in display

Refer to the “Owner’s Manual” for limitations and more details on this system before attempting to use it.

Driving mode select switches

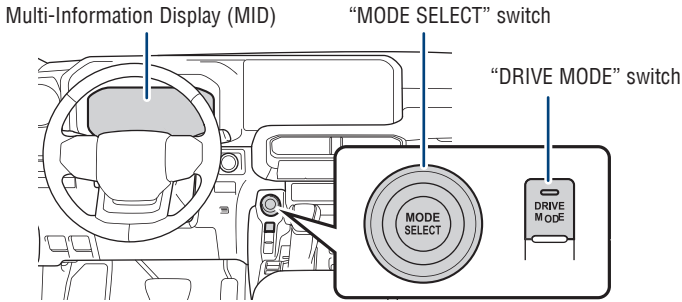

SELECTING THE DRIVING MODE

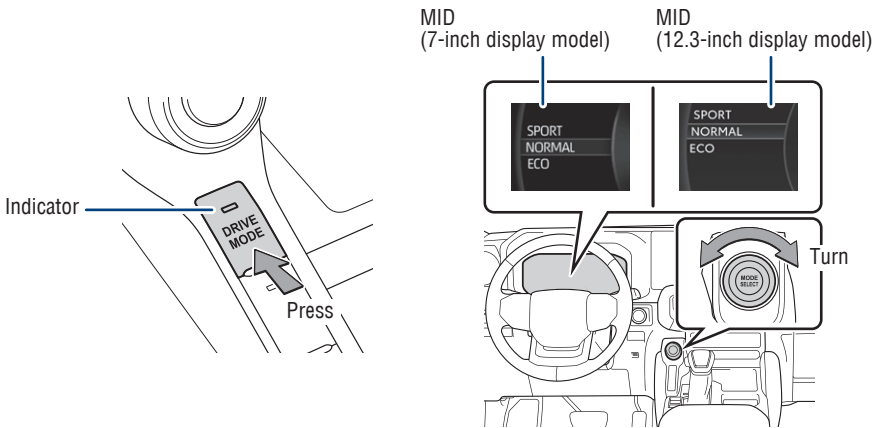

Press the "DRIVE MODE" switch. Then select the driving modes on the Multi-Information Display (MID) while turning the "MODE SELECT" switch left and right.

"NORMAL" mode: Suitable for normal driving.

"ECO" mode: Helps achieve lower fuel consumption during trips that involve frequent accelerating and braking.

"SPORT" mode: Use when a higher level of response is desired, such as when driving in mountain roads.

Refer to the "Owner's Manual" for limitations and more details on this system before attempting to use it.

Crawl Control

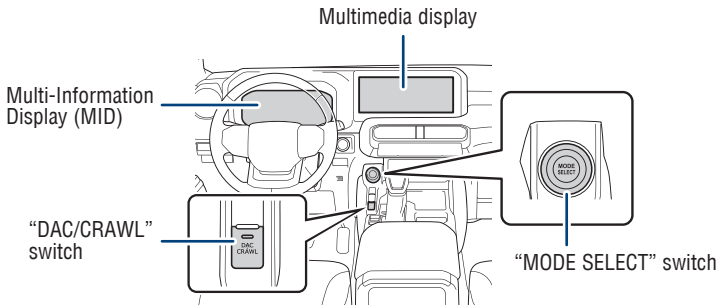

Crawl Control allows travel on extremely rough off-road surfaces at a fixed low speed without pressing the accelerator or brake pedal. Minimizes loss of traction or vehicle slip when driving on slippery road surfaces, allowing for stable driving.

SYSTEM OPERATION

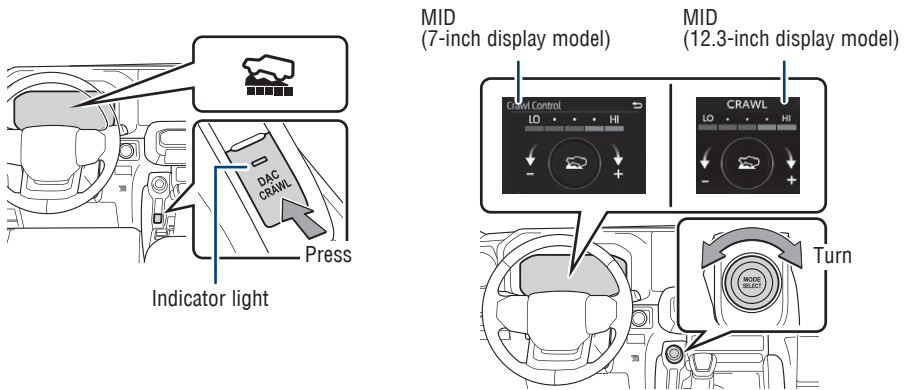

While the vehicle is on, the driver's door needs to be closed and the shift lever is in any gear other than P or N, also the front-wheel drive control is in "L4", then press the "DAC/CRAWL" switch. The the Crawl Control indicator on the Multi-Information Display (MID) will come on, and the slip indicator will flash. Then turn the mode select switch left or right to select a mode on the MID.

Turning off the system

- When the "DAC/CRAWL" switch indicator illuminates: Press the "DAC/CRAWL" switch again.
- When the "DAC/CRAWL" switch indicator does not illuminate: Press the "DAC/CRAWL" switch to turn the indicator on. Press the "DAC/CRAWL" switch again with the indicator turned on.

**Multi-information display
(7-inch display model)**

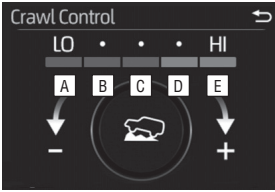

**Multi-information display
(12.3-inch display model)**

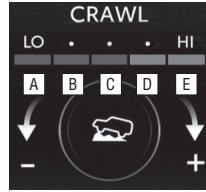

- A** “Lo”: Rocky roads or decline
- B** “Lo-Mid”: Rocky roads, decline or bumpy incline
- C** “Mid”: Bumpy inclines
- D** “Mid-Hi”: Bumpy inclines, debris roads, snow-covered roads, muddy roads, gravel roads and grass roads
- E** “Hi”: Bumpy inclines, debris roads, snow-covered roads, muddy roads, gravel roads and grass roads

Refer to the “Owner’s Manual” for limitations and more details on this system before attempting to use it.

TOW HAUL switch

**TOW
HAUL**

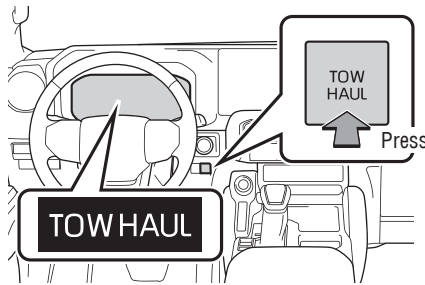

“TOW HAUL” mode is ideal for use when pulling a trailer or hauling a heavy load. Activating “TOW HAUL” mode changes engine, transmission, and steering to be more suitable when pulling a trailer.

Refer to the “Owner’s Manual” for limitations and more details on this system before attempting to use it.

FEATURES & OPERATIONS

Multi-Terrain Select (if equipped)

Multi-Information Display (MID)

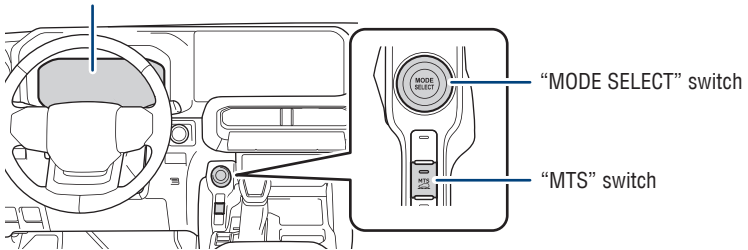

Multi-Terrain Select (MTS) is a system that improves drivability in off-road situations. Select a mode that most closely matches the type of terrain on which you are driving from several modes. Brake control, steering feel and drive force control can be optimized in accordance with the selected mode.

SYSTEM OPERATION

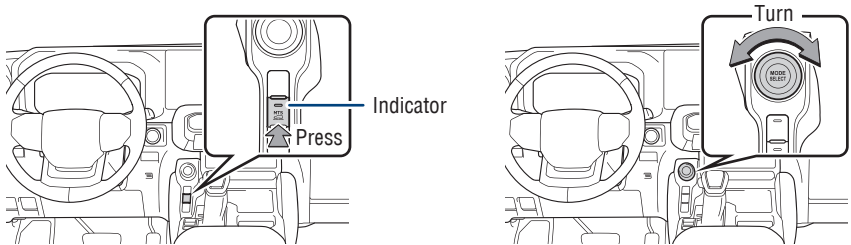

Press the "MTS" switch. Then select the Multi-Terrain Select modes on the Multi-Information Display (MID) while turning the "MODE SELECT" switch left and right.

SELECTING THE MODE

Four-wheel drive control switch is in "L4"



"AUTO": Suitable for the road conditions



"SAND": Sandy roads



"MUD": Muddy roads



"ROCK": Rocky terrain

Four-wheel drive control switch is in “H4”



“**AUTO**”: Suitable for the road conditions



“**DIRT**”: Dirt roads



“**SAND**”: Sandy roads



“**MUD**”: Muddy roads



“**DEEP SNOW**”: Deep snow roads

Refer to the “Owner’s Manual” for limitations and more details on this system before attempting to use it.

Rear view monitor system

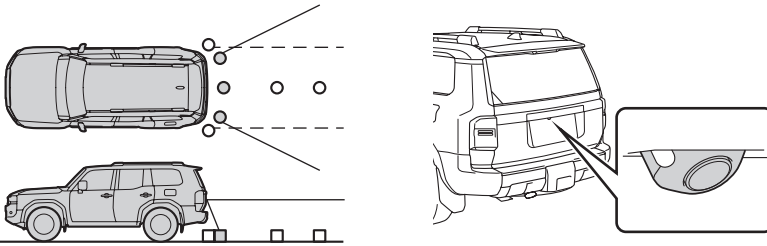

The rear view monitor system displays an image of the view from the bumper of the rear area of the vehicle. The camera for the rear view monitor system is located above the license plate.

To adjust the image on the rear view monitor screen, press “”^{*1} or “”^{*2} on the main menu on the Multimedia display and select “Display”. Select “Camera” to adjust the screen contrast and brightness.

^{*1} 7-in display, ^{*2} 12.3-in display

Refer to the “Toyota parking assist monitor” section in the “Owner’s Manual” for limitations and more details on this system.

FEATURES & OPERATIONS

Rear Camera Detection (RCD) (if equipped)

The rear camera detection (RCD) feature is designed to detect pedestrians in the detection area behind the vehicle when the vehicle is backing up. If a pedestrian is detected, a buzzer will sound and an icon will be displayed on the Multimedia Display to inform the driver of the pedestrian.



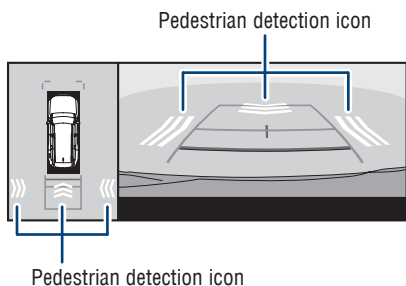

DISPLAY ON AUDIO SYSTEM SCREEN



Pedestrian detection icon:

The icon will be displayed automatically when a pedestrian is detected behind the vehicle.

SYSTEM ON/OFF

- (1) Press “<>” or “⬠” switches and select “”^{*1} or “”^{*2} from the Multi-Information Display (MID).
- (2) Press “<>” or “⬠” switches and select “ RCD” and then press “” to turn the system On/Off.
- (3) Press “” to go back to the menu.

^{*1} 7-in display, ^{*2} 12.3-in display

Refer to the “Owner’s Manual” for limitations and more details on this system before attempting to use it.

Intuitive parking assist

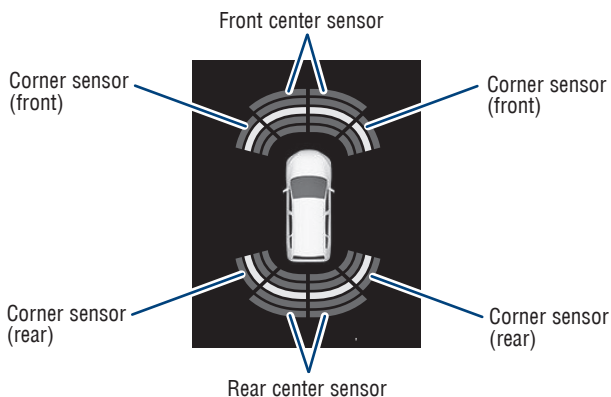





The parking assist sonar system operates when the vehicle approaches an obstacle. The distance from your vehicle to nearby obstacles when parallel parking or maneuvering into a garage is measured by sensors and communicated via the multimedia display and buzzer.

When the sensor detects an obstacle, the direction and the approximate distance to the obstacle are displayed on the multimedia display by illuminating continuously (far) or blinking (near), and beeping sounds will switch from intermittent to continuous as you approach and get closer to a detected obstacle. When the sensors detect two or more obstacles, the audible alerts will respond to the nearest zone.

Refer to the "Owner's Manual" for limitations and more details.

SYSTEM ON/OFF

- (1) Press " $\langle \rangle$ " or " \diamond " switches and select "*1 or "*2 from the Multi-Information Display (MID).
- (2) Press " $\langle \rangle$ " or " \diamond " switches and select " and then press " to turn the system On/Off.
- (3) Press " to go back to the menu.

*1 7-in display, *2 12.3-in display

Refer to the "Owner's Manual" for limitations and more details on this system before attempting to use it.

FEATURES & OPERATIONS

Blind Spot Monitor (BSM) and Rear Cross Traffic Alert (RCTA)

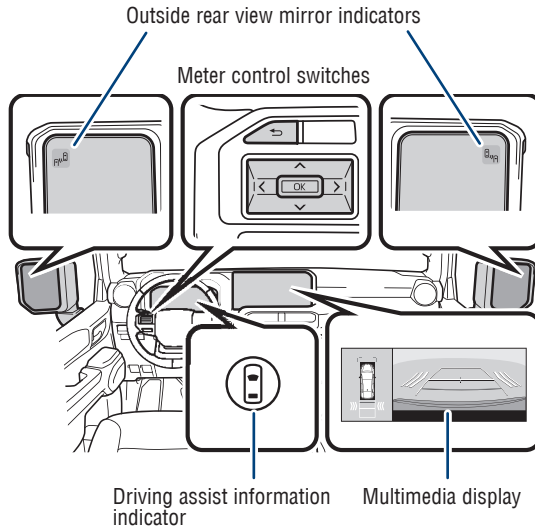

* RCTA only





BLIND SPOT MONITOR (BSM)

The system is designed to use radar sensors to detect vehicles traveling in the Land Cruiser's blind spot. If a vehicle is detected, the driver will be alerted via the outside rear view mirror indicator on the detected side.

REAR CROSS TRAFFIC ALERT (RCTA)

While in reverse, when a vehicle approaching from the right or left rear of the Land Cruiser is detected, the outside rear view mirror indicators will flash. Also, the RCTA icon for the detected side will be displayed on the audio system display, and the RCTA buzzer will sound.

SYSTEM ON/OFF

- (1) Press “<>” or “◇” switches and select “”^{*1} or “”^{*2} from the Multi-Information Display (MID).
- (2) Press “<>” or “◇” switches and select “ BSM” or “RCTA” and then press “” to turn the system On/Off.
- (3) Press “” to go back to the menu.

^{*1} 7-in display, ^{*2} 12.3-in display

Refer to the “Owner’s Manual” for limitations and more details on this system before attempting to use it.

Safe Exit Assist (SEA)

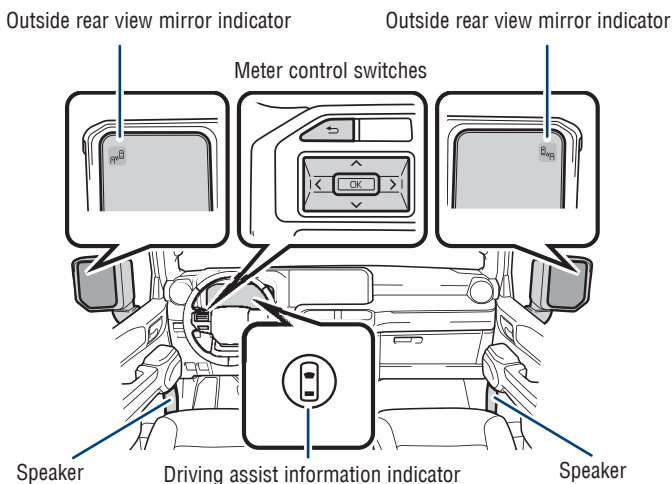

Safe Exit Assist is a system that uses rear side radar sensors installed on the inner side of the rear bumper to help warn occupants if an approaching vehicle or bicycle may collide with an opened door, before or as the door is being opened, to reduce the possibility of a collision.

SYSTEM ON/OFF

- (1) Press “<>” or “◇” switches and select “⚙️”^{*1} or “⚙️”^{*2} from the Multi-Information Display (MID).
- (2) Press “<>” or “◇” switches and select “SEA” and then press “OK” to turn the system On/Off.
- (3) Press “↶” to go back to the menu.

^{*1} 7-in display, ^{*2} 12.3-in display

Refer to the “Owner’s Manual” for limitations and more details on this system before attempting to use it.

FEATURES & OPERATIONS

Front and Rear Parking Assist with Automatic Braking (PA w/AB) (if equipped)

Front and Rear Parking Assist with Automatic Braking consists of the following functions that operate when driving at a low speed or backing up, such as when parking. When the system determines that the possibility of a collision with a detected object or pedestrian is high, a warning operates to urge the driver to take evasive action. If the system determines that the possibility of a collision with a detected object is extremely high, the brakes are automatically applied to help avoid the collision or help reduce the impact of the collision.

FUNCTIONALITY

For static objects

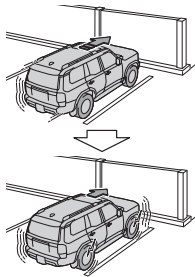

When traveling at a low speed and the brake pedal is not depressed, or is depressed late.

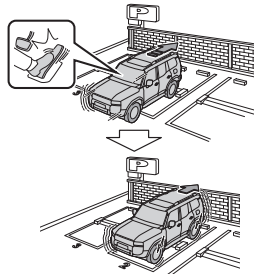

When the accelerator pedal is depressed excessively.

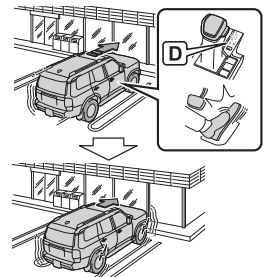

When the vehicle moves forward due to the incorrect shift position being selected.

For rear-crossing vehicles

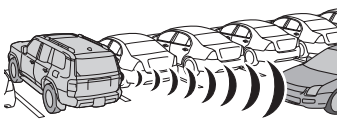

When reversing, a vehicle is approaching and the brake pedal is not depressed, or is depressed late.

For rear pedestrians

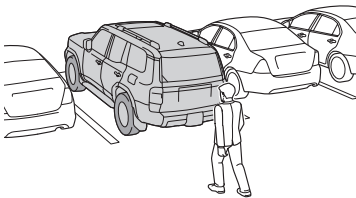

When an approaching pedestrian is detected behind the vehicle while backing up, and when the brake pedal is not depressed or is depressed late.

The pedestrian detection area differs from the Rear Camera Detection (RCD)*. Therefore in certain circumstances, RCD may detect a pedestrian and provides an alert, but automatic braking may not occur.

* If equipped

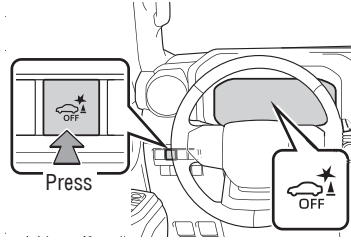

Refer to the section “Parking Support Brake function” (“static objects front and rear vehicle”, moving vehicles rear of the vehicle” and pedestrians rear of the vehicle”) in the “Owner’s Manual” for limitations and more details.

FEATURES & OPERATIONS

Multi-Terrain Monitor (if equipped)

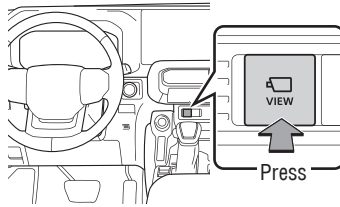

The Multi-Terrain Monitor is design to help the driver to check the vehicle surroundings. It assists in determining the conditions around the driver in a variety of situations, such as when judging conditions during off-road driving or checking for obstacles when parking.

MENU BUTTONS

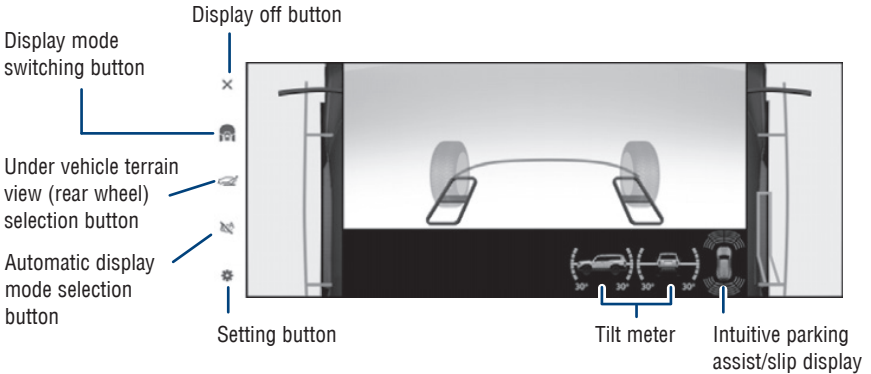

Refer to the "Owner's Manual" for limitations and more details on this system before attempting to use it.

Driver Monitor Alert (if equipped)

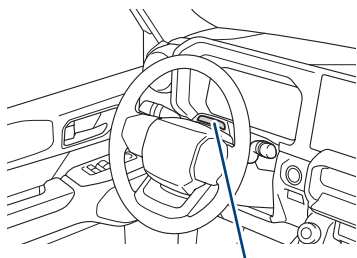

Driver monitor camera

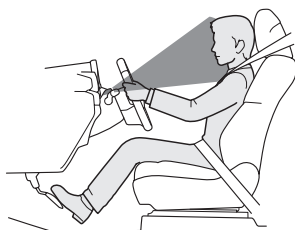

Driver monitor camera detects the position and direction the driver is facing, and whether their eyes are opened or closed. The system determines if the driver is checking their surroundings and if the driver can perform driving operations.

In situations such as the following, a buzzer will sound and a message will be displayed to warn the driver:

- When the system determines that the driver is not paying attention to the road or their eyes are closed.
- When the driver's face cannot be detected or the system determines that the driver has poor driving posture.

These functions may not operate when the vehicle speed is low.

TURNING DRIVER MONITOR ALERT ON/OFF

- (1) Press “<>” or “◇” switches and select “⚙️”^{*1} or “⚙️”^{*2} from the Multi-Information Display (MID).
- (2) Press “<>” or “◇” switches and select “🚗 Vehicle Settings” and then press and hold “OK.” The setting screen is displayed.
- (3) Press “<>” or “◇” switches and select “Driver Monitor Settings” and then press “OK.”
- (4) Press “<>” or “◇” switches and select “Driver Monitor Alert” and then press “OK” to turn the system On/Off.
- (5) Press “↩️” to go back to the menu.

^{*1} 7-in display, ^{*2} 12.3-in display

Refer to the “Owner’s Manual” for limitations and more details on this system before attempting to use it.







FEATURES & OPERATIONS

Traffic Jam Assist (TJA) (if equipped)







The Traffic Jam Assist (TJA) function, under the active supervision of the driver, provides lane keeping, accelerating/decelerating and stopping support on certain controlled access highways and expressways at vehicle speeds of approximately 25 mph (40 km/h) and below. The necessary operating conditions for this system include setting a speed using Dynamic Radar Cruise Control (DRCC) and having Lane Tracing Assist (LTA) activated. The DRCC setting “Extended Resume” Time must be set to ON. Additionally, the Driver Monitor Camera must confirm the driver is looking forward at the roadway. When TJA is operating, it is possible to take your hands off of the steering wheel.

Traffic Jam Assist is not an autonomous driving system; the driver must pay attention to the roadway and be ready to assume full control at any time.

Before using the Traffic Jam Assist function, familiarize yourself with the operation of the dynamic Dynamic Radar Cruise Control (DRCC) and the Lane Tracing Assist (LTA). Under all conditions, the driver must steer the vehicle when entering a service area/parking area or toll gate, or when changing lanes.

Display	Status	Action to be taken
	Traffic Jam Assist function is operating	–
 Gray	Traffic Jam Assist function is about to end	Hold the steering wheel.
 Orange	Traffic Jam Assist function has ended	Hold the steering wheel.
 Red	Operation of either or both of dynamic radar cruise control/LTA (Lane Tracing Assist) ended	Manually operate the steering wheel immediately.
 Yellow	Indicates that driving actions are necessary to cope with cut-in or other behavior of surrounding vehicles	The driver must operate the steering wheel, accelerator pedal and brake pedal in accordance with the surrounding environment.
	Indicates that the recording function of the driver monitor camera is operational (Blinking of this icon indicates that recording is undergoing, and constant illumination indicates ready for recording.)	–

TURNING TJA ON/OFF

- (1) Press “<>” or “↕” switches and select “”^{*1} or “”^{*2} from the Multi-Information Display (MID).
- (2) Press “<>” or “↕” switches and select “ Vehicle Settings” and then press and hold “.” The setting screen is displayed.
- (3) Press “<>” or “↕” switches and select “TrafficJamAsst” and then press “” to turn the system On/Off.
- (4) Press “” to go back to the menu.

^{*1} 7-in display, ^{*2} 12.3-in display

Refer to the Toyota “Owner’s Manual” for additional information on TJA operation, settings adjustments, limitations, and precautions before attempting to use it.

FEATURES & OPERATIONS

Front Cross Traffic Alert (FCTA) (if equipped)

When approaching an intersection, etc., at a low speed, vehicles approaching from the left and right of the front of the vehicle can be detected and the driver informed of these vehicles.

Operation of the Front Cross Traffic Alert is controlled by the following situations.

- When the system detects a vehicle approaching from the left or right of the front of your vehicle when approaching an intersection, a notification will be displayed.
- When the system determines that your vehicle may be about to enter an intersection even though a vehicle is approaching from the left or right in front of your vehicle, a buzzer will sound and a message will be displayed to urge you to depress the brake pedal.







Head-Up Display (HUD)



Multi-Information Display (MID)



TURNING FCTA ON/OFF

- (1) Press “<>” or “⬆” switches and select “”^{*1} or “”^{*2} from the Multi-Information Display (MID).
- (2) Press “<>” or “⬆” switches and select “ Vehicle Settings” and then press and hold “.” The setting screen is displayed.
- (3) Press “<>” or “⬆” switches and select “FCTA” or “Front Cross Traffic Alert” and then press “” to turn FCTA On/Off.
- (4) Press “” to go back to the menu.

^{*1} 7-in display, ^{*2} 12.3-in display

CONDITIONS WHEN FCTA WILL BE OPERATED





When all of the following conditions are met, the system will be operated:

- A shift position other than P or R is selected.
- The vehicle speed is approximately 10 mph (15 km/h) or less.
- A vehicle is approaching from the left or right of the front of your vehicle at a speed between approximately 7 to 37 mph (10 to 60 km/h).
- There are no vehicles in front of your vehicle.
- The accelerator pedal is not being strongly depressed.
- The brake pedal is not being strongly depressed.

Refer to the Toyota “Owner’s Manual” for additional information on FCTA operation, settings adjustments, limitations, and precautions before attempting to use it.

Lane Change Assist (LCA) (if equipped)

Lane Change Assist provides steering assistance during a lane change signaled by the driver while Dynamic Radar Cruise Control and Lane Tracing Assist are activated, and the vehicle speed is between approximately 55 and 85 mph (90 and 140 km/h). This function should only be used on highways and expressways. The steering assist operation can be overridden by the steering wheel operation of the driver. The lane change assist function is not designed to operate when changing lanes at a junction.

LCA display	Steering icon	Condition
 Blue arrow and white line	 Green	LCA is operating
	 Gray	Approaching vehicle detected while LCA is operating
Not displayed	 Gray	Lane line no longer detected while LCA is operating

TURNING LCA ON/OFF

- Press “<>” or “◊” switches and select “⚙️”^{*1} or “⚙️”^{*2} from the Multi-Information Display (MID).
- Press “<>” or “◊” switches and select “🚗 Vehicle Settings” and then press and hold “OK.” The setting screen is displayed.
- Press “<>” or “◊” switches and select “LCA” or “Lane Change Assist” and then press “OK” to turn LCA On/Off.
- Press “↩️” to go back to the menu.

*1 7-in display, *2 12.3-in display

OPERATING LCA

If the turn signal lever is held in the first position, the lane change direction will be displayed and the function will operate.

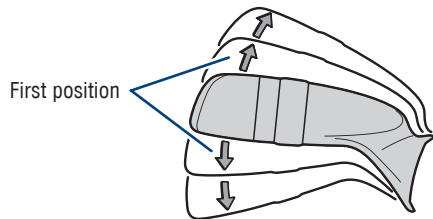
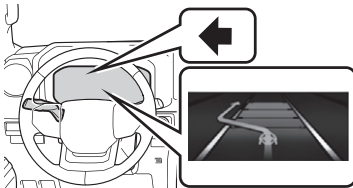

Refer to the Toyota “Owner’s Manual” for additional information on LCA operation, settings adjustments, limitations, and precautions before attempting to use it.

Quick overview-Toyota Safety Sense™ 3.0

Toyota Safety Sense™ (TSS) 3.0 is a suite of safety and driver assistance technologies designed to support driver awareness, decision making, and vehicle operation. TSS includes features such as Pre-Collision System with Pedestrian Detection, Lane Departure Alert with Steering Assist, and Dynamic Radar Cruise Control.

Refer to the Owner's Manual for details including system operation, limitations, and setting adjustments.

For more information, please visit www.toyota.com/safety-sense.



Pre-Collision System with Pedestrian Detection (PCS w/PD)

PCS w/PD is designed to provide alert, mitigation, and/or avoidance support in certain conditions, when the system determines there is potential for a collision with a detected object.

The advanced front radar system is designed to work with the forward-facing camera to help recognize a preceding vehicle, bicyclist, pedestrian or motorcyclist in certain conditions.



Lane Tracing Assist (LTA)

When driving on a road with clear lane lines with the dynamic radar cruise control operating, Lane Tracing Assist detects the lane lines and preceding and surrounding vehicles using the front camera and radar sensor, and operates the steering wheel to maintain the vehicle's lane position. LTA requires the driver to grip the steering wheel.

When LTA is activated, if the system does not detect driving operations, such as if the driver is not holding the steering wheel, and determines the driver is not responsive, the Emergency Driving Stop System (EDSS) is designed to decelerate the vehicle to a stop within its current lane to help avoid or mitigate a possible collision.



Lane Departure Alert (LDA) with Steering Assist

LDA uses the front camera to detect lane lines or certain other roadway boundaries. This system warns the driver if the vehicle may deviate from the current lane or course and also can slightly operate the steering wheel to help avoid deviation from the lane or course. If LDA detects that the vehicle is swaying, a message will be displayed and a warning buzzer will sound to urge the driver to take a break.



Full-Speed Range Dynamic Radar Cruise Control (DRCC)*

Full-Speed Range DRCC is designed to help maintain a pre-set distance to a preceding vehicle when the preceding vehicle is traveling at a lower speed.

* Available only on vehicles with automatic transmissions

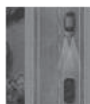

Automatic High Beams (AHB)

AHB is designed to detect the headlights of oncoming vehicles and the taillights of preceding vehicles and switch between high beams and low beams as appropriate.

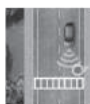

Road Sign Assist (RSA)

RSA is designed to recognize specific road signs using the forward-facing camera to provide information to the driver via the display.

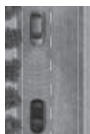

Proactive Driving Assist (PDA)

PDA uses the vehicle's camera and radar, when system operating conditions are met, to provide gentle braking and/or steering to support driving tasks such as distance control between your vehicle and a preceding vehicle, bicyclist, or pedestrian. PDA can also provide gentle braking into curves.

Over-The-Air (OTA) Updates

TSS 3.0 is capable of over-the-air updates. To use this function it is necessary to opt-in to the Connected Service Master Data Consent. In some instances when software is updated, the operating methods or functions may change. Before using the system, make sure to read the Digital Owner's Manual corresponding to the current software version, available at www.toyota.com/owners/resources/warranty-owners-manuals.

Sensors

TSS 3.0 combines a forward-facing camera mounted in front of the inside rear view mirror and a grille-mounted radar mounted in the front grille. These sensors support the driving assist systems.

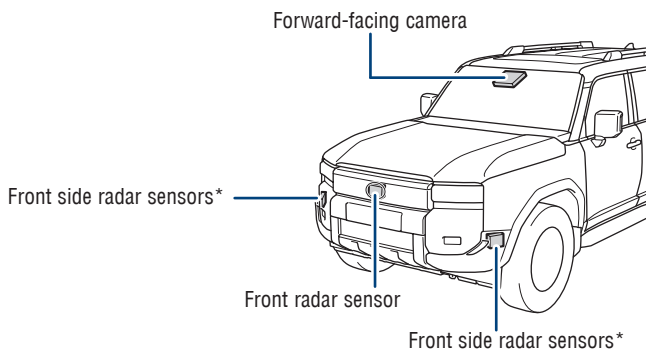

* If equipped

Pre-Collision System with Pedestrian Detection (PCS w/PD)

The Pre-Collision System with Pedestrian Detection (PCS w/PD) is designed to help detect a vehicle, bicyclist, pedestrian or motorcyclist in certain situations. Using both a camera and front radar, PCS w/ PD can provide an audio/visual alert to warn you of a possible collision under certain circumstances. If you don't react, the system is designed to automatically brake.

As there is a limit to the degree of recognition accuracy and control performance that this system can provide, do not overly rely on this system. This system will not prevent collisions or lessen collision damage or injury in every situation. Do not use PCS instead of normal braking operations under any circumstances. Do not attempt to test the operation of the Pre-Collision System yourself, as the system may not operate or engage, possibly leading to an accident. In some situations, such as when driving in inclement weather such as heavy rain, fog, snow or a sandstorm or while driving on a curve and for a few seconds after driving on a curve, a vehicle, bicyclist, pedestrian or motorcyclist may not be detected by the radar and camera sensors, preventing the system from operating or engaging properly.

Refer to the Toyota "Owner's Manual" for a list of additional situations in which the system operation may be limited.

Pre-Collision Warning

When the system determines that the possibility of a frontal collision is high, a buzzer will sound and an icon and warning message will be displayed on the Multi-Information Display (MID) to urge the driver to take evasive action.

Pre-Collision Brake Assist

If the driver notices the hazard and brakes, the system may provide additional braking force using Brake Assist. This system may prime the brakes and may apply greater braking force in relation to how strongly the brake pedal is depressed.

Pre-Collision Brake Control

If the driver does not brake in a set time and the system determines that the possibility of a collision with a preceding vehicle is extremely high, the system may automatically apply the brakes, reducing speed in order to help the driver reduce the impact and in certain cases avoid the collision.

See www.toyota.com/safety-sense for more information.

PCS PEDESTRIAN DETECTION

Under certain conditions, the PCS included with TSS 3.0 may also help to detect a pedestrian, bicyclist or motorcyclist in front of your vehicle using the forward-facing camera and the front radar sensor. The forward-facing camera of PCS detects a potential pedestrian, bicyclist or motorcyclist based on size, profile, and motion of the detected pedestrian, bicyclist or motorcyclist. However, a pedestrian, bicyclist or motorcyclist may not be detected depending on the conditions, including the surrounding brightness and the motion, posture, size, and angle of the potential detected pedestrian, bicyclist or motorcyclist, preventing the system from operating or engaging.

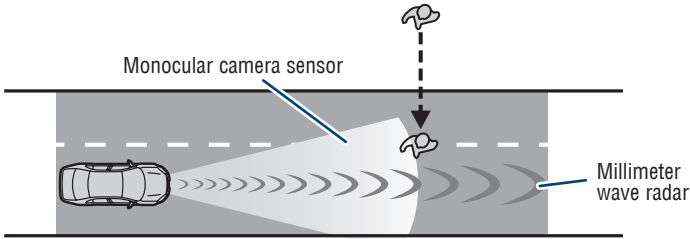

As part of the Pre-Collision System, this function is also designed to first provide an alert and then automatic braking if needed.

Refer to the Toyota "Owner's Manual" for additional limitations and information.

CHANGING PCS WARNING TIMING







- (1) Press " $\langle \rangle$ " or " \diamond " switches and select "" *1 or "" *2 from the Multi-Information Display (MID).
- (2) Press " $\langle \rangle$ " or " \diamond " switches and select " PCS" and then press and hold "". The setting screen is displayed.
- (3) Press " $\langle \rangle$ " or " \diamond " switches and select "Warning timing" and then press "" to change the desired setting. Each time it is pressed, the PCS warning timing changes "Later" or "Default" or "Earlier".
- (4) Press "" to go back to the menu.

Note: PCS is enabled each time the vehicle is turned on. The system can be disabled/enabled and the alert timing of the system can be changed. (Alert timing only, brake operation remains the same.)

*1 7-in display, *2 12.3-in display

TOYOTA SAFETY SENSE™

DISABLING PRE-COLLISION SYSTEM (PCS)

- (1) Press “<>” or “◊” switches and select “”^{*1} or “”^{*2} from the Multi-Information Display (MID).
- (2) Press “<>” or “◊” switches and select “ PCS” and then press and hold “”. The setting screen is displayed.
- (3) Press “<>” or “◊” switches and select “ PCS” and then press “” to turn PCS On/Off.
- (4) Press “” to go back to the menu.

^{*1} 7-in display, ^{*2} 12.3-in display

Refer to the Toyota “Owner’s Manual” for additional information on PCS w/PD operation, settings adjustments, limitations, and precautions before attempting to use it.









Lane Tracing Assist (LTA)

When driving on a road with clear lane lines with the dynamic radar cruise control operating, Lane Tracing Assist detects the lane lines and preceding and surrounding vehicles using the front camera and radar sensor, and operates the steering wheel to maintain the vehicle's lane position. LTA requires the driver to grip the steering wheel.

When LTA is activated, if the system does not detect driving operations, such as if the driver is not holding the steering wheel, and determines the driver is not responsive, the Emergency Driving Stop System (EDSS) is designed to decelerate the vehicle to a stop within its current lane to help avoid or mitigate a possible collision.

See www.toyota.com/safety-sense for more information.

Operation of the Lane Tracing Assist function is indicated by the following icons on the instrument cluster.

Indicator	Lane display	Steering icon	Situation
 White	 Gray/White	 Gray	LTA is on standby
 Green	 Green	 Green	LTA is operating
 Yellow Flashing	 Yellow Flashing	 Green	The vehicle is departing the lane toward the side which the lane display is flashing

Refer to the Toyota "Owner's Manual" for additional information on LTA operation, settings adjustments, limitations, and precautions before attempting to use it.

TURNING LANE TRACING ASSIST (LTA) ON/OFF

Press the LTA switch to turn LTA ON/OFF.

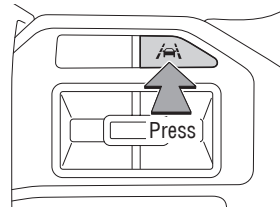

Note: Operation of LTA and setting adjustments continues in the same condition regardless of power switch modes until changed by the driver or the system is reset. The LTA indicator is illuminated when LTA is on.

Lane Departure Alert (LDA) with Steering Assist

LANE DEPARTURE ALERT (LDA) WITH STEERING ASSIST

By detecting visible lane markings or the road's edge at speeds above 30 mph, Lane Departure Alert (LDA) with Steering Assist is designed to issue a visual alert and audio or steering vibration alert if an inadvertent lane departure is detected. If the driver does not take corrective action, the Steering Assist function is designed to provide gentle corrective steering.* If LDA detects that the vehicle is swaying, a message will be displayed and a warning buzzer will sound to urge the driver to take a break.

* See www.toyota.com/safety-sense for more information and limitations.

Lane departure alert function

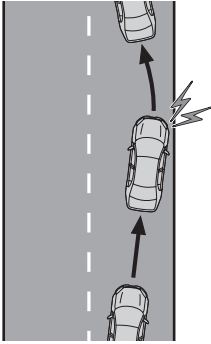

Lane departure prevention function

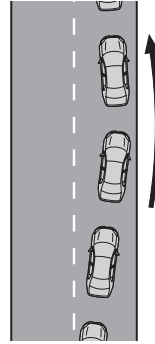



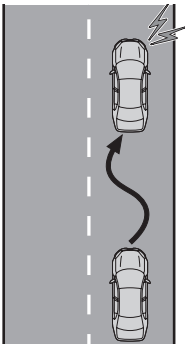









**Break suggestion function
(Sway Warning)**









LANE DEPARTURE ALERT (LDA) WITH STEERING ASSIST (CONTINUED)

Operation of the Lane Departure Alert function is indicated by the following icons on the instrument cluster.

Indicator	Lane display	Steering icon	Operation
Not illuminated	Not illuminated	Not illuminated	System disabled
 White	 Gray	Not illuminated	Lane lines are not detected by the system
 White	 White	Not illuminated	Lane lines are detected by the system
 Yellow Flashing	 Yellow Flashing	Not illuminated	Lane departure alert function is operating for the side which the lane display is flashing
 Green	 Green	 Green	Lane departure prevention function is operating for the side which the lane display is illuminated
 Yellow Flashing	 Yellow Flashing	 Green	Lane departure alert function/lane departure prevention function is operating for the side which the lane display is flashing







TURNING LDA ON/OFF

- Press “<>” or “◇” switches and select “”^{*1} or “”^{*2} from the Multi-Information Display (MID).
- Press “<>” or “◇” switches and select “ LDA” and then press and hold “”. The setting screen is displayed.
- Press “<>” or “◇” switches and select “ LDA” and then press “” to turn LDA On/Off.
- Press “” to go back to the menu.







^{*1} 7-in display, ^{*2} 12.3-in display

TOYOTA SAFETY SENSE™







ADJUSTING LDA ALERT TIMING

- (1) Press “<>” or “◇” switches and select “*1 or “*2 from the Multi-Information Display (MID).
- (2) Press “<>” or “◇” switches and select “ LDA” and then press and hold “”. The setting screen is displayed.
- (3) Press “<>” or “◇” switches and select “Alert Timing” and then press “” to change the desired setting. Each time it is pressed, the LDA alert timing changes “Default” or “Earlier”.
- (4) Press “” to go back to the menu.

ADJUSTING LDA ALERT OPTIONS

- (1) Press “<>” or “◇” switches and select “*1 or “*2 from the Multi-Information Display (MID).
- (2) Press “<>” or “◇” switches and select “ LDA” and then press and hold “”. The setting screen is displayed.
- (3) Press “<>” or “◇” switches and select “Alert Options” and then press “” to change the desired setting. Each time it is pressed, the LDA alert options changes “Vibration” or “Beep”.
- (4) Press “” to go back to the menu.

TURNING THE DRIVER BREAK SUGGESTION (SWAY WARNING) ON/OFF

- (1) Press “<>” or “◇” switches and select “*1 or “*2 from the Multi-Information Display (MID).
- (2) Press “<>” or “◇” switches and select “ Vehicle Settings” and then press and hold “”. The setting screen is displayed.
- (3) Press “<>” or “◇” switches and select “ Driver Break Suggestion” and then press “” to turn the system On/Off.
- (4) Press “” to go back to the menu.

*1 7-in display, *2 12.3-in display

Refer to the Toyota “Owner’s Manual” for additional information on LDA operation, settings adjustments, limitations, and precautions before attempting to use it.

Full-Speed Range Dynamic Radar Cruise Control (DRCC)

Intended for highway use, Full-Speed Range Dynamic Radar Cruise Control (DRCC) lets you drive at a preset speed, with a minimum set speed of approximately 20 mph. The system uses vehicle-to-vehicle distance control, helping maintain a preset distance from the vehicle ahead of you.**

** See www.toyota.com/safety-sense for more information

Refer to the Toyota "Owner's Manual" for a list of additional situations in which the system operation may be limited.

Meter display

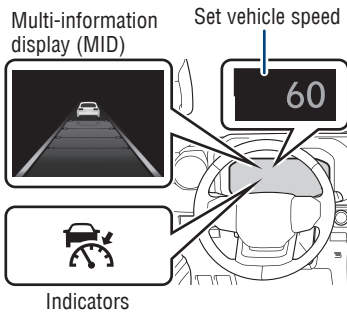

Switches

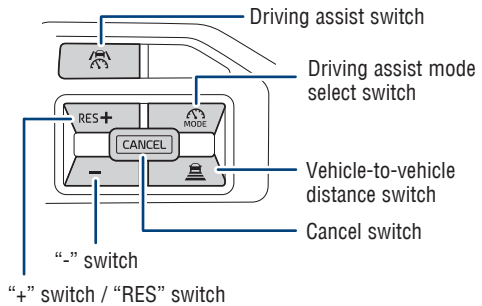

ACTIVATING DRCC

(1)

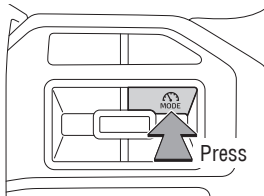

(2)

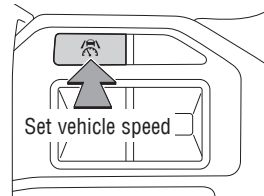

The vehicle will cruise at a set vehicle speed, decelerate to maintain a selected distance from a slower preceding vehicle and accelerate back up to the selected speed if the vehicle in front changes lanes or speeds up.

- (1) Press "MODE" switch to select DRCC. The dynamic radar cruise control indicator "MODE" will illuminate and the message "Adaptive Cruise Mode" will be displayed on the MID.
- (2) Using the accelerator pedal, accelerate or decelerate to the desired vehicle speed (approximately 20 mph [30 km/h] or more), and press "Set vehicle speed" switch to set the set vehicle speed. The set vehicle speed will be displayed on the Multi-Information Display (MID).

TOYOTA SAFETY SENSE™

ADJUSTING SET VEHICLE SPEED

(3)

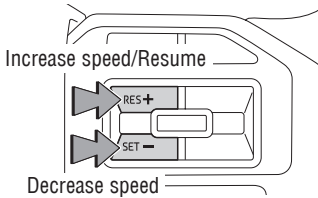

(4)

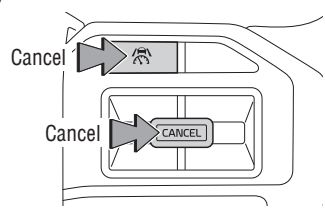

- (3) To change the set vehicle speed, press the “+” (increase) or “-” (decrease) switch until the desired speed is displayed. Press and hold to continuously adjust the speed in 1 mph (1.6 km/h) increments, or use a single press to adjust in individual increments of 1 mph (1.6 km/h).
- (4) Press “**CANCEL**” switch or “” switch to cancel the speed control. (Press the “**CANCEL**” switch to resume control.)

* The speed control may also be canceled by depressing the brake pedal.

ADJUSTING DISTANCE

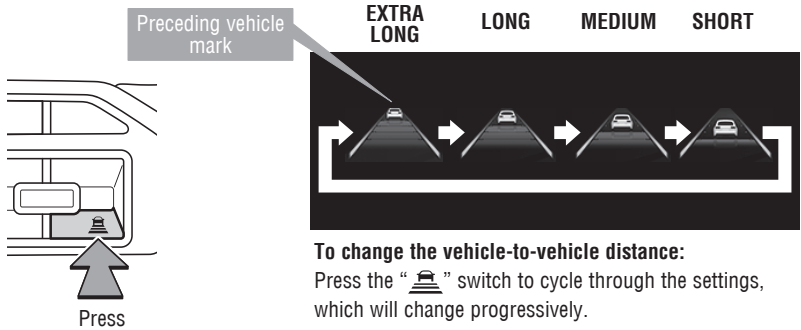

The actual vehicle-to-vehicle distance varies in accordance with the vehicle speed. Also, when the vehicle is stopped by system control, it will be stopped at a certain distance from the preceding vehicle, depending on the situation, regardless of the setting.

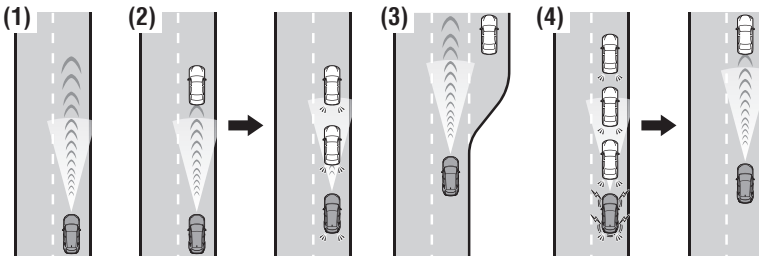

(1) **Constant speed cruising when there are no vehicles ahead**

The vehicle travels at the speed set by the driver. If the set vehicle speed is exceeded while driving down a hill, the set vehicle speed display will blink and a buzzer will sound.

(2) **Deceleration cruising and follow-up cruising when a preceding vehicle driving slower than the set vehicle speed is detected**

When a slower vehicle is detected running ahead of your vehicle, the vehicle automatically decelerates and if a greater reduction in vehicle speed is necessary, the brakes may be applied (the brake lights will come on at this time). The vehicle is controlled to maintain the vehicle-to-vehicle distance set by the driver, in accordance with changes in the speed of the preceding vehicle. If vehicle deceleration is not sufficient and the vehicle approaches the vehicle ahead, the approach warning will sound.

(3) **Acceleration when there are no longer any preceding vehicles driving slower than the set vehicle speed**

The vehicle accelerates until the set vehicle speed is reached and then resumes constant speed cruising.

(4) **Starting off**

If a preceding vehicle stops, the vehicle will also stop (controlled stop). After the preceding vehicle starts off, pressing the "RES" switch or depressing the accelerator pedal will resume follow-up cruising (start off operation). If a start off operation is not performed, the controlled stop will continue.

Note: When your vehicle is too close to a vehicle ahead, and sufficient automatic deceleration via the cruise control is not possible, the display will flash and the buzzer will sound to alert the driver. An example of this would be if another driver cuts in front of you while you are following a vehicle. Depress the brake pedal to ensure an appropriate vehicle-to-vehicle distance.

ADDITIONAL DRCC SETTINGS

- (1) Press “<>” or “◇” switches and select “⚙️”^{*1} or “⚙️”^{*2} from the Multi-Information Display (MID).
- (2) Press “<>” or “◇” switches and select “🚗 Vehicle Settings” then press and hold “OK”.
- (3) Press “<>” or “◇” switches and select “🚗 DRCC” and then press “OK”. The setting screen is displayed.
- (4) Press “<>” or “◇” switches to select a DRCC setting from the menu, and then press “OK” to change the desired setting.
- (5) Press “↩️” to go back to the menu.

^{*1} 7-in display, ^{*2} 12.3-in display

Refer to the Toyota “Owner’s Manual” for additional information on DRCC operation, settings adjustments, limitations, and precautions before attempting to use it.

Cruise Control

Intended for highway use, Cruise Control lets you drive at a preset speed. The system is designed to function at speeds greater than 20 mph.

Refer to the Toyota “Owner’s Manual” for a list of additional situations in which the system operation may be limited.

Meter display

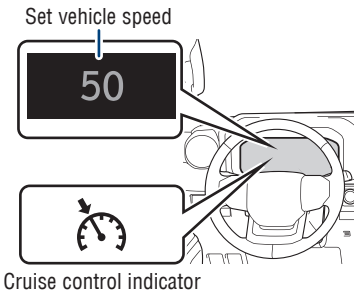

Switches

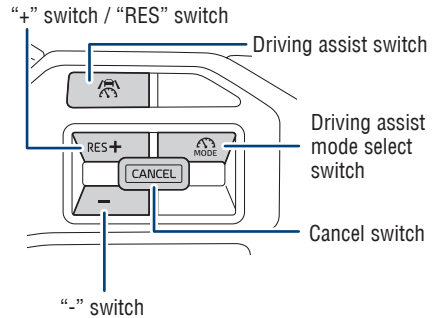

ACTIVATING CRUISE CONTROL

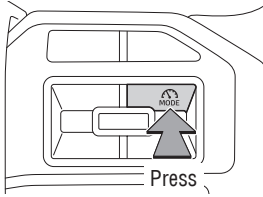

(1)

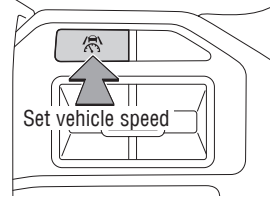

(2)



Vehicle will cruise at a set vehicle speed.

- (1) Press “MODE” switch to select “Cruise Control Mode”. The cruise control indicator “” will illuminate.
- (2) Using the accelerator pedal, accelerate or decelerate to the desired vehicle speed (approximately 20 mph [30 km/h] or more), and press “” switch to set the set vehicle speed. The set vehicle speed will be displayed on the Multi-Information Display (MID).

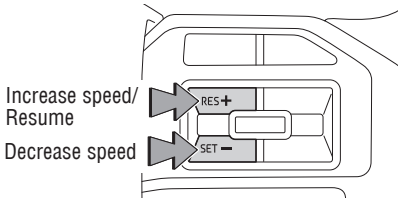

ADJUSTING SET VEHICLE SPEED

(3)

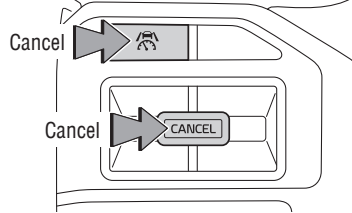

(4)



- (3) To change the set vehicle speed, press the “+” (increase) or “-” (decrease) switch until the desired speed is displayed. Press and hold to continuously adjust the speed in 1 mph (1.6 km/h) increments, or use a single press to adjust in individual increments of 1 mph (1.6 km/h).
- (4) Press “” switch or “” switch to cancel the speed control.
(Press the “” switch to resume control.)

* The speed control may also be canceled by depressing the brake pedal.

Note: NOTE: On steep downhills, or where there are sudden changes between sharp up and down gradients, vehicle speed may exceed the set speed when driving down a steep hill.

Refer to the Toyota “Owner’s Manual” for additional information on Cruise Control operation, settings adjustments, limitations, and precautions before attempting to use it.

Automatic High Beams (AHB)

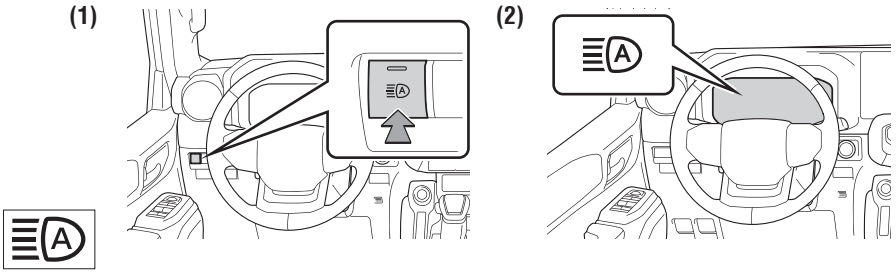



The Automatic High Beams (AHB) safety system is designed to help the driver see more clearly at night. At speeds above 21 mph, AHB can detect the headlights of oncoming vehicles and taillights of preceding vehicles, then automatically toggles between high and low beams accordingly.

See www.toyota.com/safety-sense for more information.

Refer to the Toyota “Owner’s Manual” for additional information on AHB operation, settings adjustments, limitations, and precautions before attempting to use it.

ACTIVATING THE AHB SYSTEM

- (1) Press the “” switch.
- (2) Turn the headlight switch to the “**AUTO**” or “” position.

The AHB indicator “” will come on when the headlights are on and the headlight switch lever is in the low beam position to indicate the system is active.

Note: Push the lever away from you to manually turn on high beams. Press the AHB switch to turn the AHB system off.

CONDITIONS WHERE AHB WILL TURN ON/OFF AUTOMATICALLY

When all of the following conditions are met, the high beams will be automatically turned on (after approximately 1 second):

- Vehicle speed is approximately 21 mph (34 km/h) or more.
- The area ahead of the vehicle is dark.
- There are no oncoming or preceding vehicles with headlights or taillights turned on.
- There are few streetlights or other lights on the road ahead.

If any of the following conditions occur, the high beams will be automatically turned off:

- Vehicle speed drops below approximately 17 mph (27 km/h).
- The area ahead of the vehicle is not dark.
- Oncoming or preceding vehicles have headlights or taillights turned on.
- There are many streetlights or other lights on the road ahead.

TEMPORARILY SWITCHING TO THE LOW BEAMS

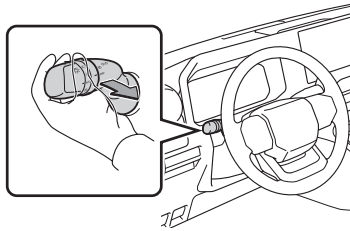

Pull the lever rearward and then return it to its original position to switch to the low beams temporarily.

The high beams will illuminate while the lever is pulled. However, after the lever is returned to its original position, the low beams will remain on for a certain period of time. Afterwards, the Automatic High Beams will be activated again.

NOTE: It is recommended to switch to the low beams when use of the high beams is inappropriate or the high beams may cause problems or distress to other drivers or pedestrians nearby.

Road Sign Assist (RSA)

Using the forward-facing camera and/or navigation system (if equipped), Road Sign Assist (RSA) is designed to detect certain road signs and display them on the instrument cluster.

All vehicle actions must be driver-initiated and are not automated. Refer to the Toyota "Owner's Manual" for additional information and limitations.

SUPPORTED TYPES OF ROAD SIGNS

The following types of road signs can be displayed.



Speed limit



Do Not Enter



No U-turn



No Turn On Red



Stop







Yield



Warning







Depending on the specifications of the vehicle, signs may be displayed overlapping.

SYSTEM ON/OFF

- (1) Press “<>” or “⬇” switches and select “”^{*1} or “”^{*2} from the Multi-Information Display (MID).
- (2) Press “<>” or “⬇” switches and select “ RSA” and then press “” to turn RSA On/Off.
- (3) Press “” to go back to the menu.

Note: If the vehicle was last turned off while a speed limit sign was displayed on the Multi-Information Display (MID), the same sign displays again when the vehicle is turned back ON.

ADDITIONAL RSA SETTINGS

- (1) Press “<>” or “⬇” switches and select “”^{*1} or “”^{*2} from the Multi-Information Display (MID).
- (2) Press “<>” or “⬇” switches and select “ RSA” and then press and hold “”. The setting screen is displayed.
- (3) Press “<>” or “⬇” switches to select an RSA setting from the menu, and press “” to select or change a desired setting.
- (4) Press “” to go back to the menu.







^{*1} 7-in display, ^{*2} 12.3-in display

Refer to the Toyota “Owner’s Manual” for additional information on RSA operation, settings adjustments, limitations, and precautions before attempting to use it.

Proactive Driving Assist (PDA)

PDA uses the vehicle's camera and radar, when system operating conditions are met, to provide gentle braking and/or steering to support driving tasks such as distance control between your vehicle and a preceding vehicle, bicyclist, or pedestrian. PDA can also provide gentle braking into curves.

SYSTEM OPERATION DISPLAY







Icon	Meaning
	<ul style="list-style-type: none"> • White: Monitoring for detectable objects • Green: Detectable object crossing the road or detectable object on the side of the road assistance operating
	A pedestrian has been detected as crossing the road or on the side of the road and brake or steering assistance is operating
	A vehicle has been detected on the side of the road and brake or steering operation assistance is being performed
	<ul style="list-style-type: none"> • Steering operation assistance is being performed to prevent the vehicle from approaching too close to a detectable object on the side of the road • When the steering assist is operating
	Preceding vehicle deceleration assistance is being performed
	Warning to maintain appropriate vehicle-to-vehicle distance
	Curve deceleration assistance is being performed

TURNING PDA ON/OFF

- (1) Press “<>” or “⬠” switches and select “⚙️”^{*1} or “⚙️”^{*2} from the Multi-Information Display (MID).
- (2) Press “<>” or “⬠” switches and select “(PDA) PDA” and then press “OK” to turn PDA On/Off.
- (3) Press “↩️” to go back to the menu.

^{*1} 7-in display, ^{*2} 12.3-in display







ADJUSTING PDA SUPPORT TIMING

- (1) Press “<>” or “◇” switches and select “*1 or “*2 from the Multi-Information Display (MID).
- (2) Press “<>” or “◇” switches and select “() PDA” and then press and hold “”. The setting screen is displayed.
- (3) Press “<>” or “◇” switches and select “Sensitivity” and then press “” to change the desired setting. Each time it is pressed, the timing options changes “Later”, “Default” or “Earlier”.
- (4) Press “” to go back to the menu.

OBSTACLE ANTICIPATION ASSIST (OAA)

Obstacle Anticipation Assist (OAA) is designed to detect vehicles parked on the side of the road, or pedestrians or bicyclists on the side of the road or crossing the road, and depending on the circumstances, OAA may provide mild braking and/or steering assist to control distance between the detected object and the vehicle. This system operates at vehicle speeds of approximately 20-35 mph (30-60 km/h).







TURNING OBSTACLE ANTICIPATION ASSIST (OAA) ON/OFF

- (1) Press “<>” or “◇” switches and select “*1 or “*2 from the Multi-Information Display (MID).
- (2) Press “<>” or “◇” switches and select “() PDA” and then press and hold “”. The setting screen is displayed.
- (3) Press “<>” or “◇” switches and select “OAA” or “Obstacle Anticipation Assist” and then press “” to turn the system On/Off.
- (4) Press “” to go back to the menu.

DECELERATION ASSIST (DA)

Deceleration Assist (DA) is designed to provide braking assist and gently reduce vehicle speed when the system detects preceding vehicles or certain upcoming curves in the road and the driver is not pressing on the accelerator or brake pedals. This feature operates at speeds above approximately 15 mph (20 km/h). DA does not provide steering support and will not bring the vehicle to a complete stop.







TURNING DECELERATION ASSIST (DA) ON/OFF

- (1) Press “<>” or “◇” switches and select “*1 or “*2 from the Multi-Information Display (MID).
- (2) Press “<>” or “◇” switches and select “() PDA” and then press and hold “”. The setting screen is displayed.
- (3) Press “<>” or “◇” switches and select “DA” or “Deceleration Assist” and then press “” to turn the system On/Off.
- (4) Press “” to go back to the menu.

STEERING ASSIST (SA)

PDA Steering Assist (SA) is designed to detect the lines of the roadway and vary the assistance from the power steering to help the driver stay within the lane. Steering Assist does not actively steer the vehicle. This feature is designed to operate at vehicle speeds between 5-80 miles per hour and does not require DRCC to be engaged.

TURNING STEERING ASSIST (SA) ON/OFF

- (1) Press “<>” or “◊” switches and select “”^{*1} or “”^{*2} from the Multi-Information Display (MID).
- (2) Press “<>” or “◊” switches and select “ PDA” and then press and hold “”. The setting screen is displayed.
- (3) Press “<>” or “◊” switches and select “SA” or “Steering Assist” and then press “” to turn the system On/Off.
- (4) Press “” to go back to the menu.

^{*1} 7-in display, ^{*2} 12.3-in display

Refer to the Toyota “Owner’s Manual” for additional information on PDA operation, settings adjustments, limitations, and precautions before attempting to use it.

SAFETY & EMERGENCY FEATURES

Seat belts

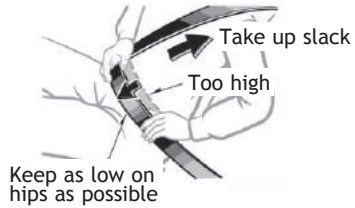

NOTE: If a passenger's seat belt is fully extended, then retracted even slightly, the Automatic locking retractor (ALR) will prevent it from being re-extended beyond that point, unless fully retracted again. This feature is used to help hold child restraint systems securely.

To find more information about seat belts, and how to install a child restraint system, refer to the "Owner's Manual".

Seat belts-Shoulder belt anchor

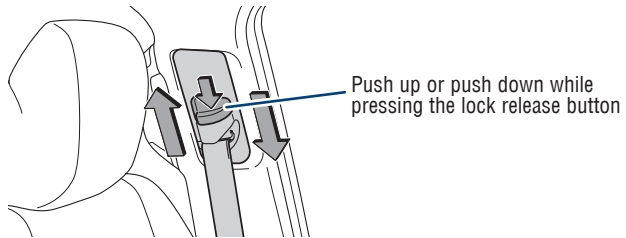

Rear door child safety locks

Rear door

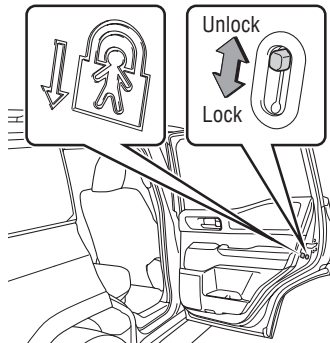

Moving the lever downward will allow the door to be opened only from the outside.

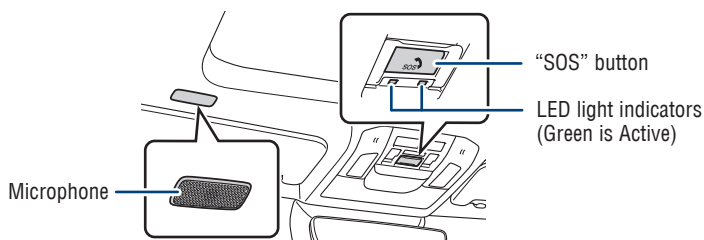

Safety Connect is a subscription-based telematics service that uses Global Positioning System (GPS) data and embedded cellular technology to provide safety and security features to subscribers. Safety Connect is staffed with live agents at the Toyota response center, which operates 24 hours per day, 7 days per week.

Services for subscribers include:

- Automatic collision notification
- Stolen vehicle locator
- Emergency assistance (“SOS” button)
- Enhanced roadside assistance

For limitations and additional information, refer to the “Owner’s Manual” or visit www.toyota.com/connected-services.

SAFETY & EMERGENCY FEATURES

Spare tire & tools

TOOL LOCATION

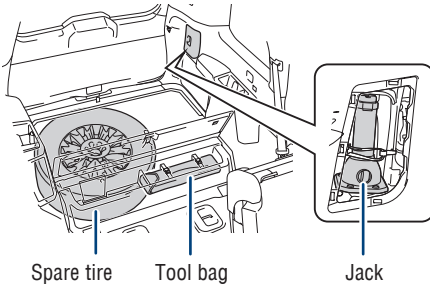

TOOLS

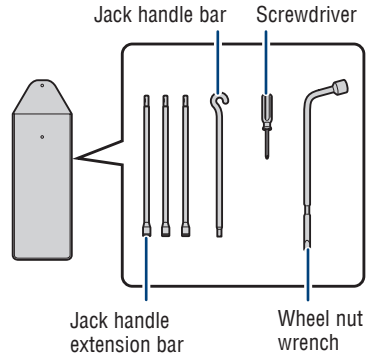

REMOVING THE SPARE TIRE

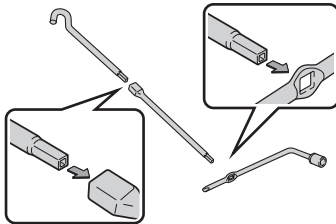

- (2) Insert the jack handle end into the lowering screw.

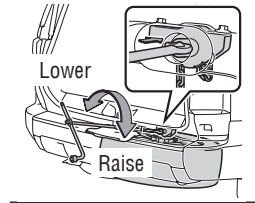

- (3) Turn the jack handle counterclockwise to lower the spare tire completely to the ground.

Refer to the "Owner's Manual" for tire changing and jack positioning procedures.

Tire pressure warning system (TPWS)

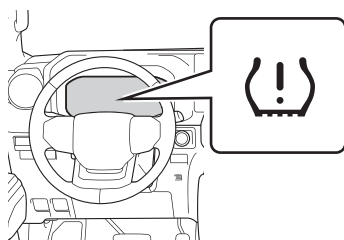

The tire pressure warning system can be selected on “”^{*1} or “”^{*2} of the Multi-Information Display (MID).

System reset initialization

- (1) Press “” or “” switches and select “”^{*1} or “”^{*2} from the Multi-Information Display (MID).
- (2) Press “” or “” switches and select “Vehicle Settings”.
- (3) Press “” or “” switches and select “TPWS Setting”.
- (4) Press “” or “” switches and select “Tyre Pressure Setting”.
- (5) Press “” or “” switches and select “Setting by Specified Pressure” and then select the desired front and rear tire pressures.

OR

- (5) Press “” or “” switches and select “Setting by Current Pressure”.
- (6) Press “” or “” switches and select “Yes”.

The tire pressure warning light will slowly blink 3 times and a message will be displayed on the MID.

The tire pressure detected by the tire pressure warning system can be displayed on the Multi-Information Display (MID).

If the tire pressure indicator flashes for approximately 1 minute and then remains on, take the vehicle to your local Toyota dealer.

Refer to the load label on the door jamb or the “Owner’s Manual” for tire inflation specifications.

NOTE: The warning light may come on due to temperature changes or changes in tire pressure from natural air leakage. If the system has not been initialized recently, setting the tire pressures to factory specifications should turn off the light.

^{*1} 7-in display, ^{*2} 12.3-in display

SAFETY & EMERGENCY FEATURES

Star Safety System™

Your vehicle comes standard with the Star Safety System™, which combines Anti-lock Braking System (ABS), Brake Assist (BA), Electronic Brake-force Distribution (EBD), Smart Stop Technology (SST), Traction Control (TRAC) and Vehicle Stability Control (VSC).

Refer to the “Owner’s Manual” for more details and important information on limitations to these systems.

ANTI-LOCK BRAKE SYSTEM (ABS)

Toyota’s Anti-lock Brake System detects which wheels are locking up and limits wheel lockup by “pulsing” each wheel’s brakes independently. Pulsing releases brake pressure repeatedly for fractions of a second. This helps the tires attain the traction that current road conditions will allow, helping you to stay in directional control.

BRAKE ASSIST (BA)

Brake Assist is designed to detect sudden or “panic” braking, and then add braking pressure to help decrease the vehicle’s stopping distance. When there’s only a split second to react, Brake Assist can add additional brake pressure more quickly than just the driver alone can.

ELECTRONIC BRAKE FORCE DISTRIBUTION (EBD)

Toyota’s ABS technology has Electronic Brake-force Distribution (EBD) to help maintain control and balance when braking. EBD responds to sudden stops by redistributing brake force to enhance the braking effectiveness of all four wheels.

SMART STOP TECHNOLOGY (SST)

Smart Stop Technology automatically reduces engine power when the accelerator and brake pedals are pressed simultaneously under certain conditions. SST engages when the accelerator is depressed first and the brakes are applied firmly for longer than one-half second at speeds greater than five miles per hour. SST doesn’t engage if the brake pedal is depressed before the accelerator pedal, allowing vehicles to start on a steep hill and safely accelerate without rolling backward.

VEHICLE STABILITY CONTROL (VSC)

VSC helps prevent loss of traction during cornering by reducing engine power and applying brake force to selected wheels.

Toyota's VSC monitors steering angle and the direction your vehicle is traveling. When it senses that the front or rear wheels begin to lose traction, VSC reduces engine power and applies braking to selected wheels. This helps restore traction and vehicle control.

TRACTION CONTROL (TRAC)

VSC helps prevent loss of traction during cornering by reducing engine power, and Traction Control helps maintain traction on loose gravel and wet, icy, or uneven surfaces by applying brake force to the spinning wheel(s).

Toyota's TRAC sensors are activated when one of the drive wheels starts to slip. TRAC limits engine output and applies the brakes to the spinning wheel. This transfers power to the wheels that still have traction to help keep you on track.

SAFETY & EMERGENCY FEATURES

Floor mat installation

There are two types of Toyota floor mats: carpeted and all-weather. Each vehicle has model-specific floor mats. Installation is easy.

To keep your floor mat properly positioned, follow these steps:

- Only use Toyota floor mats designed for your specific model.
- Only use one floor mat at a time, using the equipped fasteners to keep the mat in place.
- Install floor mats right side up.

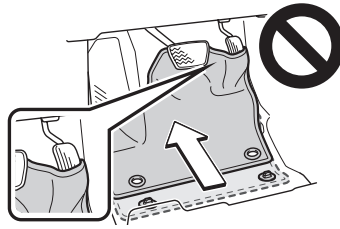
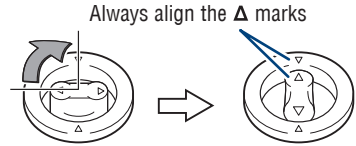
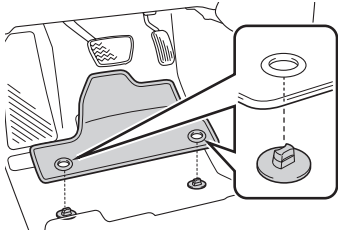

GETTING STARTED WITH TOYOTA AUDIO MULTIMEDIA AND CONNECTED SERVICES

- Registering Your Vehicle
- Toyota App
- Bluetooth® Pairing
- Connected Services
- Connected Technology Support
- Apple CarPlay®
- Android Auto™
- SiriusXM®
- Updating System Software

Scan QR Code to Download Toyota app:

Apple



Android



Connected Technology Support



Visit the Toyota Connected Technology Support site for the latest instructions and setup of your Connected Technology services.

Do not attempt the process while driving.

Registering Your Vehicle

Please visit <https://toyotaaudioandconnectedservicesupport.com> for the most up to date instructions.



Toyota App



TOYOTA

Toyota app allows access to valuable information about your vehicle and control of capable features equipped with your vehicle.

- Manuals & Warranties
- Schedule Maintenance
- Roadside Assistance
- Vehicle Health Report
- SiriusXM[®] Radio
- Safety Recalls
- Toyota Financial Services - Vehicle Payment

Remote Connect equipped vehicle functions (*if equipped):

- Lock/Unlock
- Start Vehicle*
- Vehicle Finder
- Guest Driver settings
- Hazard Lights On
- Head Lights ON
- Horn Alert
- Buzzer
- Hatch/Trunk Lock/Unlock

Scan QR Code to Download Toyota app.

Apple



Android



Or

Search "Toyota" at your applicable app store.



If you have a Toyota Owner's account, use your credentials to "Sign In" and get started with Toyota app.

Or

If you do not have a Toyota Owner's account, "Register" now to get started with Toyota app.



Bluetooth® Pairing¹

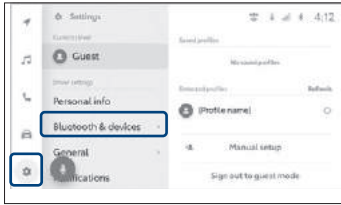

Note:
Do not attempt the Bluetooth® Pairing process while driving.

STEP 1 Select [GEAR ICON] from the main menu, then “Bluetooth & Devices”.



iPhone Bluetooth Menu



Android Bluetooth Menu

STEP 2 Ensure Bluetooth is turned on for your phone.

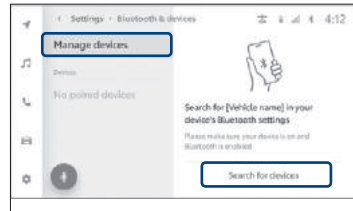

STEP 3 Select “Manage devices”, then “Search for devices”.

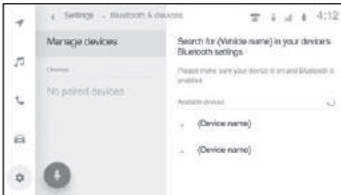

STEP 4 Select “Device name” to register.

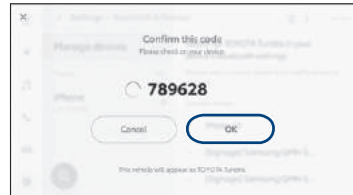

STEP 5 Check that the displayed PIN code matches the PIN code displayed on the Bluetooth® device, and then select [OK].

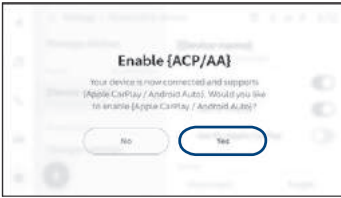

STEP 6 If your device supports Apple CarPlay / Android Auto, select “Yes” to enable.



STEP 7 While pairing your device, a message may display asking to check your device to allow syncing contacts and allow messaging.

Note: You may also select “Skip” on display screen to skip enabling notifications. If skipped, proceed to [STEP 9](#).



STEP 8 Turn on “Show Notifications” for iPhone® or “ON” for Android.

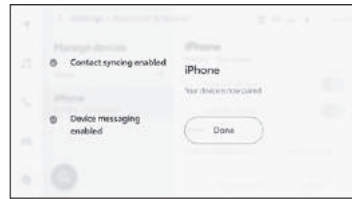

STEP 9 A confirmation will appear once your phone has been paired and connected.

GETTING STARTED WITH

Connected Services²

Your vehicle may come available with a trial period for the following Connected Services.

Learn more at www.toyota.com/connected-services/.

Safety Connect³

- (SOS) EMERGENCY ASSISTANCE BUTTON
- AUTOMATIC COLLISION NOTIFICATION
- ROADSIDE ASSISTANCE
- STOLEN VEHICLE LOCATOR

Remote Connect⁴ (*if equipped)

- START VEHICLE*
- VEHICLE STATUS ALERTS
- HAZARD LIGHTS ON
- HORN ALERT
- HATCH/TRUNK LOCK/UNLOCK
- LOCK/UNLOCK VEHICLE DOORS
- VEHICLE FINDER
- HEAD LIGHTS ON
- BUZZER

Completing the registration process is required to enable Remote Connect.

Service Connect⁵ (if equipped)

- VEHICLE HEALTH REPORT
- VEHICLE MAINTENANCE ALERT NOTIFICATION

Completing the registration process is required to enable Service Connect.

Drive Connect

- CLOUD NAVIGATION
- DESTINATION ASSIST
- INTELLIGENT ASSISTANT

Wi-Fi Connect⁷

Multiple mobile devices

- Connect up to 5 Wi-Fi enabled devices
- Passengers can use smartphones, laptops and tablets

Infotainment

- Browse the internet
- Send and receive email
- Stay connected on social media
- Access favorite apps
- Stream movies

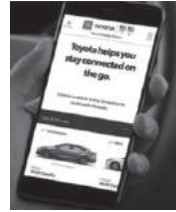

Several factors may affect smartphone and/or system performance including:

1. Smartphone operating system software version
2. Smartphone battery power level
3. Poor cellular reception to the smartphone
4. Multiple applications running on a smartphone at the same time
5. Charge/media cable quality
6. Smartphone operating system updates may also affect Toyota app functionality

For additional information, please visit: www.toyota.com/connected-services

Connected Technology Support

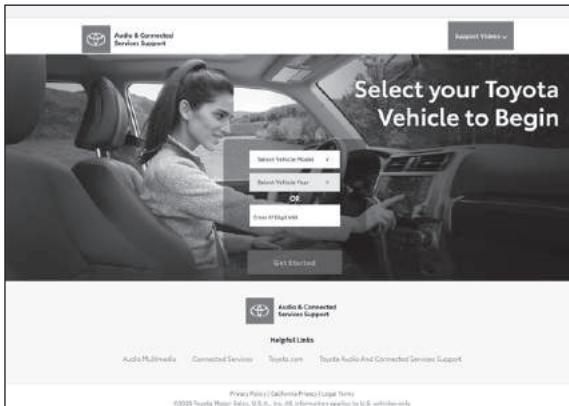

Toyota's online support tool provides intuitive "How-To" instruction and videos.

To begin, please visit: <https://toyotaaudioandconnectedservicesupport.com/>.

Or Scan the QR code below:



GETTING STARTED WITH

Apple CarPlay® (Compatible iPhone® required)

Setup of Apple CarPlay®



STEP 1 Ensure Siri® is enabled on your phone.



STEP 2 Plug a compatible iPhone® into the USB media port using an Apple® approved cable or have the smartphone and vehicle connected through Bluetooth®.

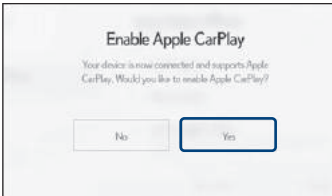

STEP 3 On the multimedia system, select “Yes” when asked if you would like to Enable Apple CarPlay®.



STEP 4 Select Allow to use CarPlay® while the phone is locked.

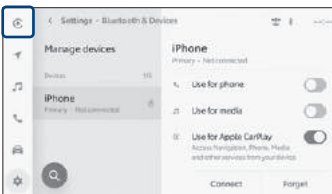

* Screen depiction accurate at time of posting.

STEP 5 To launch Apple CarPlay®, select the Apple CarPlay® icon on the top of the side menu bar.



* Screen depiction accurate at time of posting.

STEP 6 Apple CarPlay® is now ready to operate. You can go back to the Toyota multimedia system by using the Toyota icon in the Apple CarPlay® screen.

Requirements:

Bluetooth® functions will be inoperable while CarPlay® is in use. Wireless CarPlay® is supported. Features may vary by vehicle model and phone.

To learn more about how your iPhone® works with CarPlay® visit: <https://support.apple.com/en-us/HT205634>

To view a full list of CarPlay® supported apps visit: <https://www.apple.com/ios/carplay/>

Siri® through CarPlay®

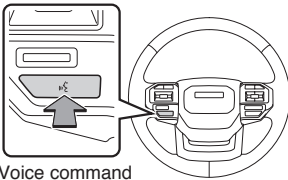

Voice command talk switch

Press and hold the voice command talk switch for 2-3 seconds to activate.



* Screen depiction accurate at time of posting.

Once Siri® is activated you can ask to: make calls, send and receive text messages, listen to music and more.

Android Auto™ (Compatible Android™ device required)

Setup of Android Auto™



STEP 1 With Android 9 or below, the Android Auto™ app download is required. With Android 10, Android Auto™ is built in and the app is NOT required.



STEP 2 Open Android Auto™ app and tap get started.



STEP 3 Ensure Android Auto™ is enabled on the phone.



STEP 4 Plug a compatible Android™ smartphone into the USB media port using an Android approved cable or have the smartphone and vehicle connected through Bluetooth®.

Android Auto™ (Compatible Android™ device required) (continued)

Setup of Android Auto™ (continued)

STEP 5 On the multimedia system, select “Yes” when asked if you would like to Enable Android Auto™.

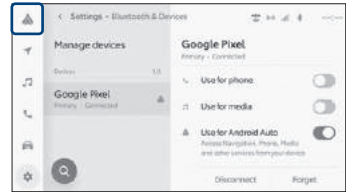

STEP 6 To launch Android Auto™, select the Android Auto™ icon on the top of the side menu bar.



* Screen depiction accurate at time of posting.

STEP 7 Android Auto™ is now ready to operate. You can go back to the Toyota multimedia system by using the Toyota icon in the Android Auto™ screen.

Requirements:

Bluetooth® functions will be inoperable while Android Auto™ is in use. Wireless Android Auto™ is supported. Features may vary by vehicle model and phone.

To learn more about how to use Android Auto™ visit: <https://www.android.com/auto>

Google Assistant through Android Auto™

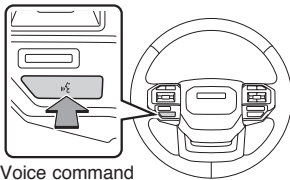

Voice command talk switch

Press and hold the voice command talk switch for 2-3 seconds to activate.



* Screen depiction accurate at time of posting.

Once Google Assistant is activated, you can ask to: make calls, send and receive text messages, listen to music and more.

SiriusXM® 8 (If equipped)

SiriusXM® Audio

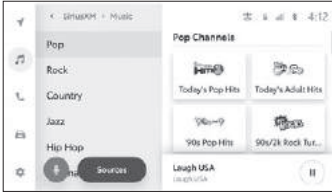

* Screen depiction accurate at time of posting.

Toyota vehicles equipped with SiriusXM® come with a 3-month trial subscription. You get 425+ channels, including 165+ channels in your vehicle to enjoy ad-free music, plus sports, news, talk, comedy and more. Experience even more on the SiriusXM® App, featuring a collection of podcasts, Xtra channels of music, personalized Pandora® stations, SiriusXM video and more.



Updating System Software

The Toyota Audio Multimedia system is capable of over-the-air, over Wi-Fi®, and through USB flash drive updates. To use this function it is necessary to opt-in to the Connected Service Master Data Consent. When the Toyota Audio Multimedia system software is updated, the operating methods of functions may change. Each update will identify the proper updating method to one or all of the following methods:

- Update the software using the Data Communication Module (DCM)
- Update the software using Wi-Fi
- Update the software using a USB flash drive

See the Owner's Manual for complete details on the updating procedure.

After updating make sure to read the Digital Navigation Owner's Manual corresponding to the current software version available at <https://www.toyota.com/owners/resources/warranty-owners-manuals>.

GETTING STARTED WITH

Privacy & Protection

To learn about Toyota's Connected Services data collection, use, sharing and retention, visit: www.toyota.com/privacyvts.

- 1 The Bluetooth word mark and logos are registered trademarks owned by Bluetooth SIG, Inc. and any use of such marks by Toyota is under license. A compatible Bluetooth enabled phone must first be paired. Phone performance depends on software, coverage and carrier.
- 2 Visit Toyota.com/connected-services or see your local Toyota Dealer for additional details.
- 3 Safety Connect depends on an operative telematics device, a cellular connection, GPS signal strength and other factors outside of Toyota's control, all of which can limit system functionality or availability, including access to response center and emergency support. Stolen vehicle police report required to use Stolen Vehicle Locator. Some features may require the Toyota app. Registration required. Subscription required after trial. Service subject to change at any time without notice. Terms of Use apply. Data charges may apply. Service may vary by vehicle and region. See usage precautions and service limitations in Owner's Manual and Toyota.com/connected-services/ for additional details.
To learn about Toyota's data collection, use, sharing and retention practices, please visit <https://www.toyota.com/privacyvts/>.
- 4 Toyota - Remote Connect
Use only if aware of circumstances surrounding vehicle and it is legal and safe to do so (e.g., do not remotely start engine if vehicle is in an enclosed space or vehicle is occupied by a child). Toyota Remote Connect depends on an operative telematics device, a cellular connection, GPS signal strength and other factors outside of Toyota's control, which can limit system functionality and availability. Service may vary by vehicle and region. Registration and Toyota app download required. Subscription required after trial. Terms of Use apply. Data charges may apply. Remote start/stop not available on manual transmission-equipped vehicles. Services subject to change at any time without notice. See usage precautions and service limitations in Toyota Owner's Manual and <https://www.toyota.com/connected-services> for additional details.
To learn about Toyota's data collection, use, sharing and retention practices, please visit <https://www.toyota.com/privacyvts/>.
- 5 Service Connect information provided is based on the last time data was collected from the vehicle and is not real time data. Service Connect depends on an operative telematics device, a cellular connection, GPS signal strength and other factors outside of Toyota's control, which can limit functionality or availability. Service may vary by vehicle and region. Registration required. Subscription required after trial. Service subject to change at any time without notice. Terms of Use apply. Data charges may apply. See usage precautions and service limitations in Owner's Manual and Toyota.com/connected-services for additional details.
To learn about Toyota's data collection, use, sharing and retention practices, please visit <https://www.toyota.com/privacyvts/>.
- 6 Destination Assist depends on an operative telematics device, a cellular connection, navigation map data and GPS signal strength and other factors outside of Toyota's control, which can limit system ability functionality or availability. Use common sense when relying on this information. Service may vary by vehicle and region. Registration required. Subscription required after trial. Services subject to change at any time without notice. Terms of Use apply. Data charges may apply. See Owner's Manual and Toyota.com/connected-services for additional limitations and details.
To learn about Toyota's data collection, use, sharing and retention practices, please visit <https://www.toyota.com/privacyvts/>.
- 7 Wi-Fi Connect is available on select 2018 and newer Toyota vehicles.
Visit Toyota.com/connectedservices for vehicle availability.
- 8 SiriusXM® audio services require a subscription sold separately by Sirius XM Radio Inc. To cancel, you must call SiriusXM at 1-866-635-2349. See SiriusXM Customer Agreement for complete terms at www.siriusxm.com.
All fees and programming subject to change. Not all vehicles or devices are capable of receiving all services offered by SiriusXM.
SiriusXM and all related marks and logos are trademarks of Sirius XM Radio Inc.



LAND CRUISER

Quick Reference Guide 2024



00505QRG24LC



Printed in U.S.A. 2/24
24-MKG-18465

toyota.com